

---

Autodesk® PowerMill®

# MTD User Guide





# Contents

<b>Introduction</b>	<b>1</b>
Coordinates, workplanes and distances .....	3
<b>Preparing CAD Data in PowerShape</b>	<b>6</b>
Loading and organising the CAD data .....	6
<b>Moving the Machine into the origin position</b>	<b>7</b>
Importing External Components .....	8
Exporting Machine Tool Entities .....	9
<b>Folder Structure</b>	<b>10</b>
*.mtd File Structure .....	10
<b>Editing the *.mtd file for tool change simulation</b>	<b>12</b>
Attaching a tool to a machine part .....	12
Defining moves before and after a tool change .....	12
Limiting commands to pickup or putdown .....	13
Hiding static components .....	13
Specifying a tool change time .....	13
<b>Machine description</b>	<b>14</b>
<b>Description of PostProcessor Solver</b>	<b>17</b>
Description of the attach points .....	18
Creating the tool-change point .....	21
Description of static elements .....	25
Transparency or opacity of the machine parts (if necessary) .....	29
Collision detection .....	31
<b>Description of the movable elements</b>	<b>34</b>
Head-Head .....	35

Head-Table.....	36
Table-Table (Trunion) .....	37
Direction of movement in The Head block.....	45
Description of the movable elements: The table .....	46

## **How to get XYZ values in PowerShape 48**

Head-Head machine tools .....	48
Table-Table machine tools .....	51
Table-Table machine tools .....	54

## **Autodesk Legal Notice 59**

# Introduction

This guide describes how to create an MTD file and how to modify an existing MTD file to suit a particular application. It includes descriptions of the components of MTD files and machine tool simulation.

To use this guide, you must have:

- A CAD model for the machine tool. This includes the spindle, machine head, table and any other aspects of the machine you want to simulate, such as the bed and the housing.
- A technical data sheet, with information about:
  - Axis limits.
  - Axis lengths.
  - Dimensions.
  - Home positions (distance between table and spindle).
  - Coordinates of the tool changes.
- CAD models of the external components. This includes items which are not linked to the machine tool, such as fixtures and controllers.
- A Text editor and source code editor, such as Notepad++, for use with Microsoft Windows.

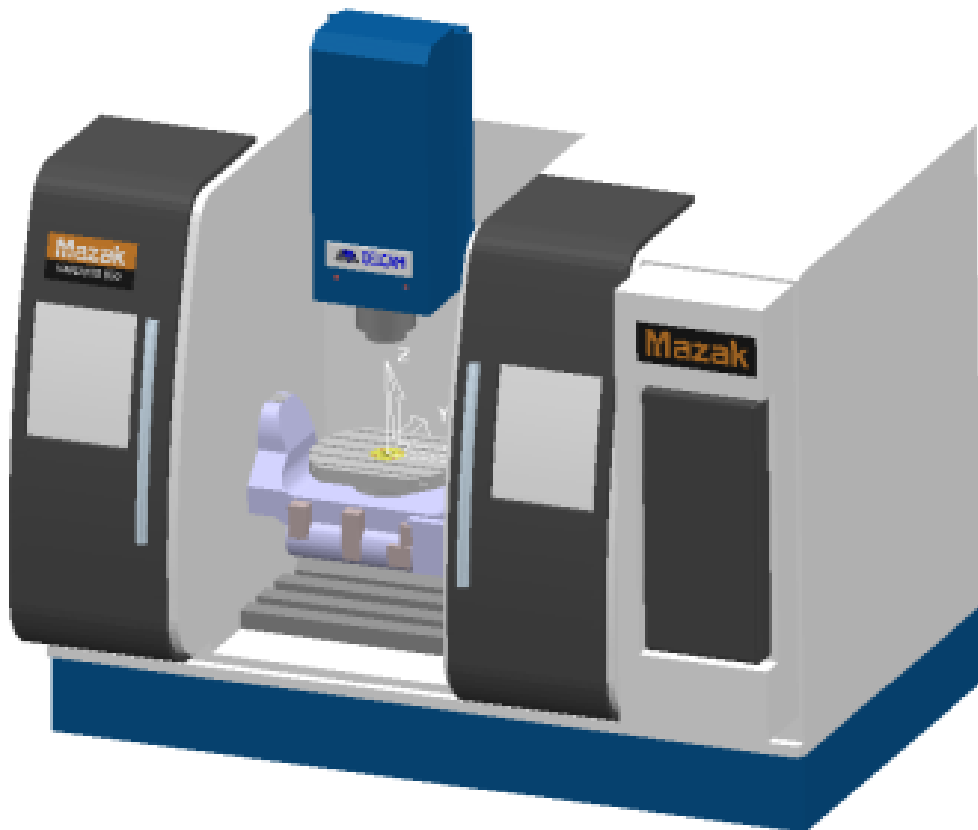

---

# Coordinates, workplanes and distances

## World Workplane Position

When you assemble the machine tool CAD data in PowerShape, the centre of the table is located at the world coordinate (0, 0, 0). All other parts of the machine tool are located with reference to this position. The spindle should be located at **Home** or **Z-Maximum** position.

## Zero Position

This is the position you want the machine tool to return to when you click **Home** in PowerMill. It is the position of the model that makes up the machine tool as it appears in PowerShape.

If the **World Workplane** position or the **Zero** position are incorrect, save the parts of the machine in the correct position. This also applies to PowerShape: you can move or rotate parts of machine to the correct position.

Incorrect **World Workplane** position:

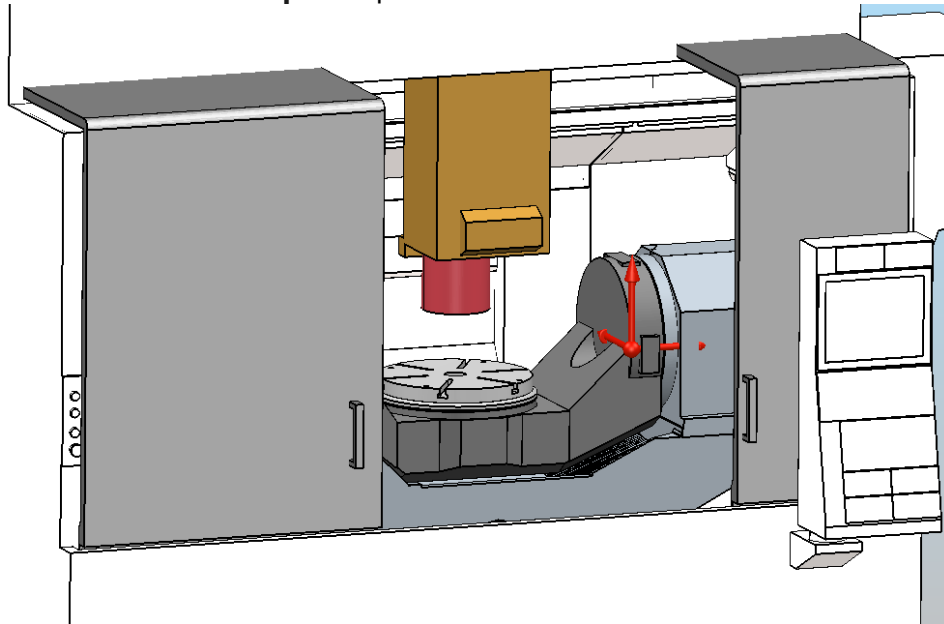

Correct **World Workplane** position:

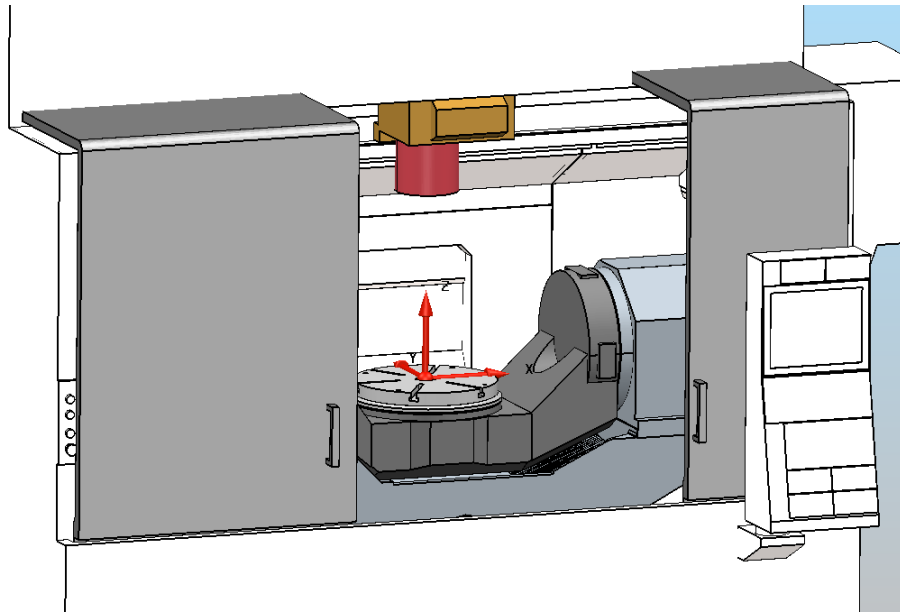

## Axes Directions

The movement of a machine tools axis, whether linear or rotational, is defined in the \*.mtd file as a vector value (i, j and k). It is important that you check which direction you want an axis to move.

- **Axis Limits** — Verify the minimum and maximum allowable movement value for each axis of the machine tool. This can be found from the machine tool manufacturer's technical data.
- **Head Attach Point** — This is the point where the tool attaches to the spindle. It should be given as XYZ value and also include the orientation of the tool axis vector as an IJK value. It is best practice to measure this coordinate within PowerShape (use tools to create geometry at the centre of the spindle tip).

The following diagram shows the linear and rotary vectors of movement:

- around linear X-axis is the **A** rotary axis.
- around linear Y-axis is the **B** rotary axis.
- around linear Z-axis is the **C** rotary axis.

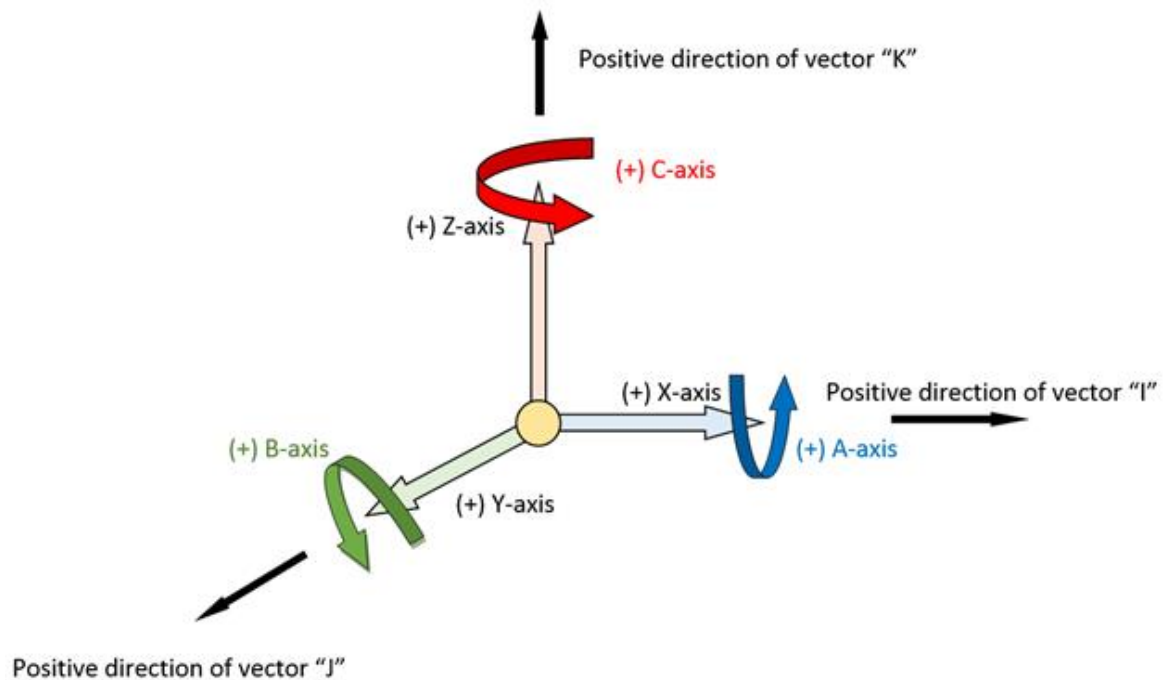

In some cases, there are machines with more than 6 axes that are not kinematic. In this case, use another capital letters, such as **D**, **F**, and **G**.

# Preparing CAD Data in PowerShape

---

## Loading and organising the CAD data

You can obtain the data from the machine tool manufacturer or you can model it yourself. The first step is to load and arrange the data you have in PowerShape. You can remove unnecessary surfaces or solids, and then assign each axis model onto separate PowerShape levels.

It is advisable to label axes by their type, for example, X, Y, Z, A, B, C, Head, Bed and Table.

# Moving the Machine into the origin position

To create a link between the world coordinates of PowerShape and PowerMill, it is advisable to position the machine so that the **World Workplane** position is located at the centre of the table of the machine.

The next step is to move the axes of the machine tool into the correct position, if necessary.

The machine tool model data may set the **Home** position of an axis to an inappropriate position. For example the Z axis may be set to a position either touching or just above the machine table. In this instance you may want to change the position of the Z axis so that when it imported into PowerMill it is clear of the model.

The following graphic shows:

- Centre of table:
  - **X=0**
  - **Y=0**
  - **Z=0**
- Centre of nose spindle:
  - **X=0**
  - **Y=0**
  - **Z=550**

The position of the **Z** axis component from the **World Workplane** must be measured and recorded in PowerShape if it is positioned from its zero point, as this is used in the \*.[mtd](#) file. This is the value of the gauge face and is crucial in attaching the tool to the machine tool. The rotation centre must be measured and recorded for later use.

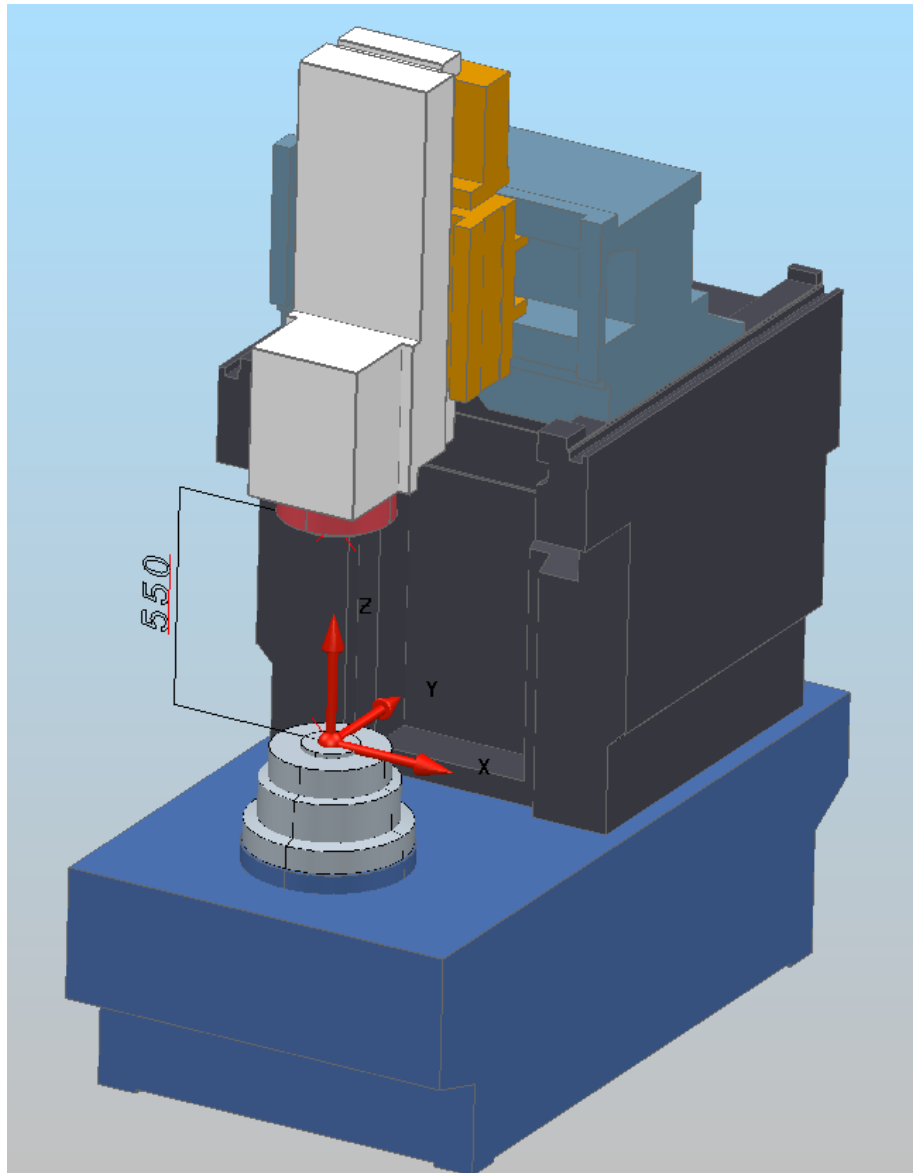

---

## Importing External Components

If the machine tool contains a housing, tool-changer, controller or other static entities, they must be imported or created now and positioned correctly. The machine tool model must represent the machine that is being simulated.

## Exporting Machine Tool Entities

Each axis of the machine tool (for example, the spindle, table, housing and the logos) must be exported into separate \*.dmt files so you can simulate them and edit their colour. See the example below machine tool **Hermle\_C12\_SRT320**.

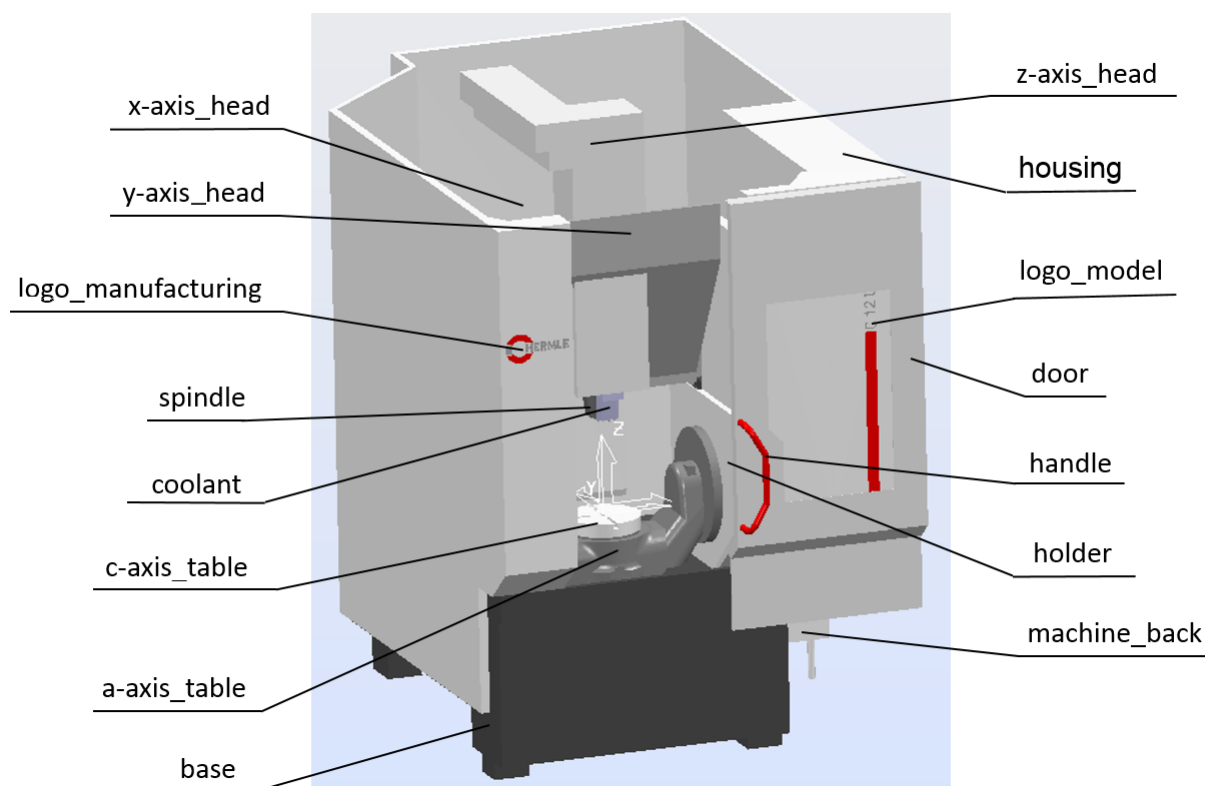

The \*.dmt file contains triangles: the more triangles, the better the simulation appears. However, with more triangles, the simulation and collision-checking run more slowly.

Choose a tolerance value:

- A tolerance value of 0.025 mm is recommended as a good balance between quality and file size for: upper surfaces of table, spindle and some other important parts in simulations (the movable parts in working area).
- A tolerance value of 0.05 mm is recommended as a good balance between quality and file size for: parts of linear and rotary movements (X-axis; Y-axis; Z-axis and additional equipment).
- A tolerance value of 0.25mm is recommended as a good balance between quality and file size for static parts, logo, base, cnc controller and other stationary elements.

If the simulation runs too slowly, reduce the triangulation tolerance value. All parts included on \*.mtd should not occupy more than 3-5 MB of memory.

The tolerance values are specified in the PowerShape Options dialog. To view or change the settings, select File > Options > Application Options > Data Exchange > Triangle/Mesh.

# Folder Structure

You must have:

- A folder containing all of the \*.dmt files for the machine tool.
- The \*.mtd file which describes the kinematics of the machine tool.

---

## \*.mtd File Structure

An \*.mtd file has details of the solver needed to drive the machine tool. It also defines the attach points for the head and table of the machine tool. The remainder of the file is made up of objects called `machine_part`. There are two `machine_part` objects which must exist. They are called `head` and `table`. Their names must be written in lower case.

A `machine_part` can have:

- Other `machine_part` objects associated with it



*An axial component can be a child of another component, which is important when dealing with the various multi axis configurations.*

- Axis controls associated with it.
- \*.dmt files associated with it.
- Axis controls:
  - Linear or rotational movement.
  - Rotary controls must have an address letter associated to them (typically designated as A, B or C).
  - Travel and angular limits can be defined.
  - X, Y and Z coordinates. X, Y and Z can be orientated anywhere as long as they are orthogonal.



*Only right handed axis systems are supported.*

The types of axis that can be configured are:

- `simple_linear` which requires direction.
- `simple_rotary` which requires a position and a direction.



To reverse a rotation direction, reverse the direction of vectors. Remember to reverse linear direction vector, if the table controls the axis.

When you want to create an \*.mtd file, you can install the text editor on your computer, for example Notepad++



You can download Notepad++ from <http://notepad-plus-plus.org/download>). In the **Main** toolbar, select **Language > XML**.

An \*.mtd can consist of 6 blocks:

- Machine description (header).
- Description of PostProcessor Solver.
- Description attach points (`table_attach_point` and `head_attach_point`).
- Description of static elements.
- Description of the movable elements. The `head`.
- Description of the movable elements. The `table`.

The following is an example \*.mtd:

<pre>&lt;?xml version="1.0" ?&gt; &lt;!-- ***** --&gt; &lt;!-- Machine Tool Manufacturer : _____ --&gt; &lt;!-- Machine Tool Model      : _____ --&gt; &lt;!-- Machine Tool Type       : _____ --&gt;  &lt;!--           When          : _____ --&gt; &lt;!--           Checked By    : _____ --&gt; &lt;!-- ***** --&gt;</pre>	1
<pre>&lt;machine xmlns="x-schema:PowermillMachineTool" POST="pmpMultiaxis.*"&gt;</pre>	2
<pre>  &lt;table_attach_point PART="table" X="0" Y="0" Z="0"/&gt;   &lt;head_attach_point  PART="head"  X="0" Y="220" Z="430" I="0" J="0" K="1"/&gt;</pre>	3
<pre>&lt;!-- ===== The static parts ===== --&gt;   &lt;machine_part&gt;           &lt;/machine_part&gt;</pre>	4
<pre>&lt;!-- ===== The head ===== --&gt;   &lt;machine_part&gt;           &lt;machine_part NAME="head" /&gt;     &lt;/machine_part&gt;</pre>	5
<pre>&lt;!-- ===== The table ===== --&gt;   &lt;machine_part&gt;           &lt;machine_part NAME="table" /&gt;     &lt;/machine_part&gt; &lt;/machine&gt;</pre>	6

# Editing the \*.mtd file for tool change simulation

---

## Attaching a tool to a machine part

Each `<machine_part>` has a list of tools connected to it. Use the `TOOLPASS` `"PART_NAME"` command to pass a tool to a part. This removes the tool from the machine-tool or part and attaches it to the machine part. It is treated as a part of the model for that part and is moved with the part

---

## Defining moves before and after a tool change

Use `<tool_change_pre_moves>` to define moves before a tool change and `<tool_change_post_moves>` to define moves after a tool change. This makes it easier to implement multiple tool changers. For example:

```
<machine>
<tool_change>
<tool_change_pre_moves/>
<tool_change_moves NUMBER="1"/>
<tool_change_moves NUMBER="2"/>
<tool_change_post_moves/>
</tool_change>
<tool_change>
<tool_change_pre_moves/>
<tool_change_moves NUMBER="3"/>
<tool_change_moves NUMBER="4"/>
<tool_change_post_moves/>
</tool_change>
</machine>
```

---

## Limiting commands to pickup or putdown

You can limit PowerMill to use commands only when a tool is being picked up or put down:

- Pick up — Use a prefix of `GETONLY`.
- Put down — Use a prefix if `PUTONLY`.

Prefixes are followed by a colon, for example:

```
<tool_change_moves NUMBER="1">
MOVETO A0
# Put the tool down and pass it to the tool changer
PUTONLY: TOOL PASS "TOOLCHANGER"
# Pick the tool put and pass it to the machine
GETONLY: TOOLCHANGE
MOVETO A90
</ tool_change_moves>
```

---

## Hiding static components

There is a `HIDDEN` axis priority that behaves like the `STATIC` priority but does not show in the **Machine Tool Position** dialog. For example:

```
<machine_part>
<axis>
<control_info ADDRESS="T" HOME="0" VALUE="0" PRIORITY="HIDDEN" />
<simple_rotary X="0" Y="2550" Z="0" I="0" J="0" K="1" />
</axis>
</machine_part>
```

---

## Specifying a tool change time

You can specify the time (in milliseconds) it takes for a tool to move. Add a `TIME` argument after the `MOVETO` command, for example:

```
<tool_change_moves NUMBER="1">
MOVETO A0 TIME=50
TOOLCHANGE
MOVETO A90 TIME=50
</tool_change_moves>
```

The time you specify is a target, as collision checking takes precedence over the competition of a move within a specified time.

# Machine description

The machine description can include the following information:

- The Machine Tool Manufacturer.
- The Machine Tool Model.
- The Machine Tool Type.
- The Machine Tool Configuration.
- The Linear Axes Limits.
- The Rotary Axes Limits (if these exist).
- The Component Tolerance (0.025, 0.05, 0.25).
- The name of the person that built the \*.mtd file.
- The date the \*.mtd file was built.
- The name of the person that tested the \*.mtd file (if necessary).
- Any problems that were fixed in the \*.mtd file.



*This information should be presented as **User Comments**.*

```

1  <?xml version="1.0" ?>
2  <!-- ***** -->
3  <!-- Machine Tool Manufacturer : Hermle -->
4  <!-- Machine Tool Model      : Hermle C12 SRT320 -->
5  <!-- Machine Tool Type       : 5-Axis Mill -->
6  <!-- Machine Tool Configuration : 5-Axis Table-Table -->
7  <!-- Linear Axis Limits      : Xmin -175 Xmax +175 -->
8  <!--                          : Ymin -220 Ymax +220 -->
9  <!--                          : Zmin +100 Zmax +430 -->
10 <!-- Rotary Axial Limits     : Amin -115 Amax +115 -->
11 <!--                          : Bmin -      Bmax -      -->
12 <!--                          : Cmin -inf Cmax -inf -->
13 <!-- Component Tolerance     : 0.025,0.05,0.25 -->
14 <!-- ***** -->
15 <!-- Who                      : xpolk -->
16 <!-- When                     : 23.10.2014 -->
17 <!-- Checked By               : Name of Colleague -->
18 <!-- Checked                  : Date Checked -->
19 <!-- Revision                 : 1.001 -->
20 <!-- Why                      : _____ -->
21 <!-- Fixed                    : _____ -->
22 <!-- ***** -->
23 <!-- Hermle_C12_SRT320 -->
24

```

Where:

<!-- starts a comment.

--> closes a comment.



*If you use XML, user comments are highlighted in green.*

See an example of the text below:

```
<!-- *****-->
<!-- Machine Tool Manufacturer      : Hermle           -->
<!-- Machine Tool Model            : Hermle C12 SRT320   -->
<!-- Machine Tool Type             : 5-Axis Mill       -->
<!-- Machine Tool Configuration    : 5-Axis Table-Table -->
<!-- Linear Axis Limits            : Xmin -175  Xmax +175 -->
<!--                               : Ymin -220  Ymax +220 -->
<!--                               : Zmin +100  Zmax +430 -->
<!-- Rotary Axial Limits           : Amin -115  Amax +115 -->
<!--                               : Bmin -      Bmax -      -->
<!--                               : Cmin -inf   Cmax -inf   -->
<!-- Component Tolerance           :    0.025, 0.05, 0.25 -->
<!-- *****-->
<!--                               Who           : xpolk           -->
<!--                               When          : 23.10.2014      -->
<!--                               Checked By   : Name of Colleague -->
<!--                               Checked      : Date Checked     -->
<!--                               Revision     : 1.002            -->
<!--                               Why          : Fixed wrong position-->
<!-- 12.01.2015                    Fixed      : fixed hierarchy   -->
<!-- *****-->
<!-- Hermle_C12_SRT320 -->
```

# Description of PostProcessor Solver

Below is a screenshot of the **PostProcessor Solver**:

```
23 <!-- Hermle_C12_SRT320 -->
24
25 <machine xmlns="x-schema:PowermillMachineTool" POST="pmpMultiaxis.*">
26
```

POST is the most important part here as it tells PowerMill how or where to drive the machine tool simulation. You must have the correct string in the [MTD](#) file as **PostProcessor** is used to drive the [MTD](#) file. What you see in PowerMill is also what the post outputs to the machine. Without that string, you cannot guarantee that the [MTD](#) and the posted code match.

Below the text example of PostProcessor Solver:

```
<machine xmlns="x-schema:PowermillMachineTool" POST="pmpMultiaxis.*">
```

Also, without the DPP solver, you cannot use the orientation vector functionality.

# Description of the attach points

## Table Attach Point as written in \*.mtd

This line defines the centre point of the machine table. The machine assembly done in PowerShape should be set up so that the table centre is placed at the world coordinate, which is 0, 0, 0.

```
<table_attach_point PART="table" X="0" Y="0" Z="0"/>
```

All other parts of the machine tool are then attached with reference to its position.

```
26  
27 <table_attach_point PART="table" X="0" Y="0" Z="0"/>  
28 <head_attach_point PART="head" X="0" Y="220" Z="430" I="0" J="0" K="1"/>  
29
```

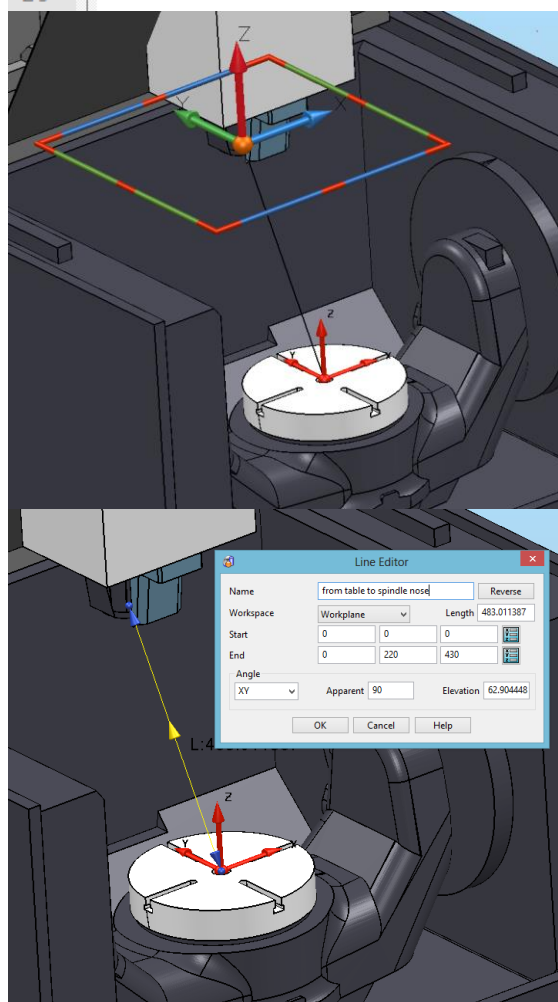

## Head Attach Point as written in \*.mtd

This line defines the tool attach point. The centre point of the machine spindle gauge face should be given here as the X, Y, Z value and the spindle axis vector should also be given as an I, J, K value.

```

27 <table_attach_point PART="table" X="0" Y="0" Z="0"/>
28 <head_attach_point PART="head" X="0" Y="220" Z="430" I="0" J="0" K="1"/>
29

```

The vectors  $I$ ,  $J$ , and  $K$  define the tool direction:

- To achieve a tool axis direction along the positive  $Z$  axis:
  - $I=0$
  - $J=0$
  - $K=1$
- To achieve a tool axis direction along the positive  $Y$  axis:
  - $I=0$
  - $J=1$
  - $K=0$
- To achieve a tool axis direction along the positive  $X$  axis:
  - $I=1$
  - $J=0$
  - $K=0$

In this case:

```

<head_attach_point PART="head" X="0" Y="220" Z="430" I="0" J="0"
K="1"/>

```

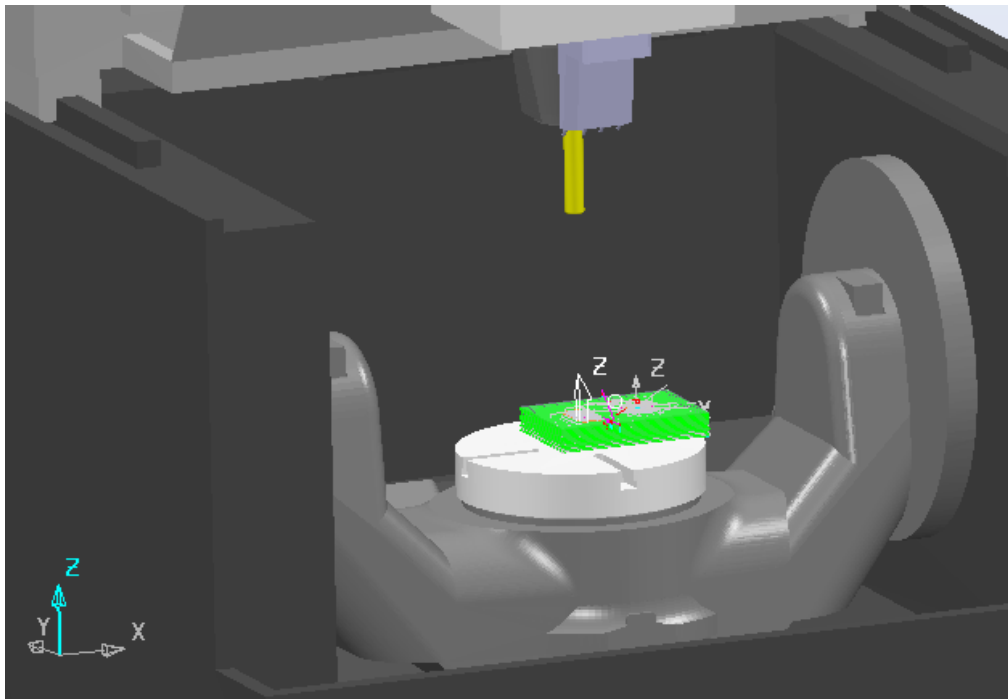

If you

change the direction of the vectors in the `head_attach_point` line for this machine,  $I="0"$   $J="0"$   $K="1"$  on  $I="1"$   $J="0"$   $K="0"$  this gives:

```

26
27 <table_attach_point PART="table" X="0" Y="0" Z="0"/>
28 <head_attach_point PART="head" X="0" Y="220" Z="430" I="1" J="0" K="0"/>
29

```

This gives the following result:

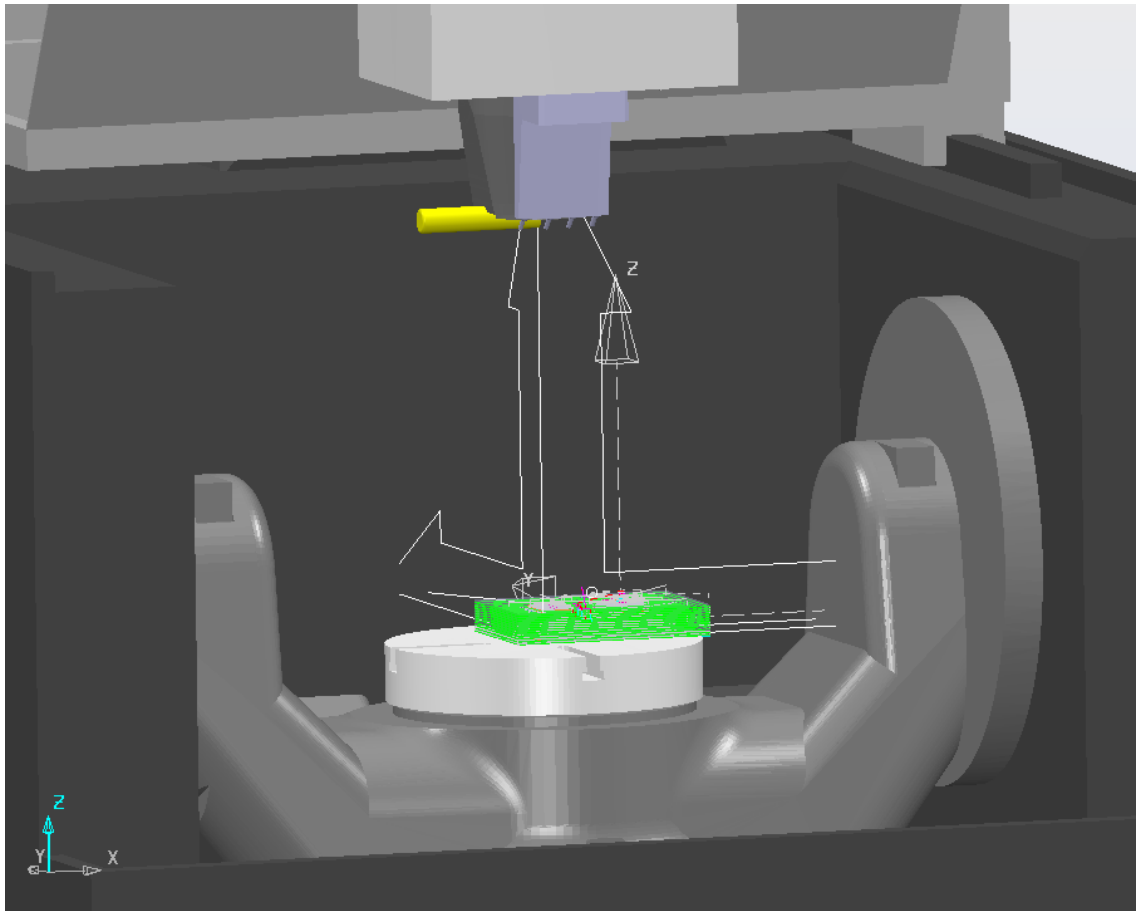

The tool (yellow cylinder) is in a horizontal position.



*This is the wrong tool position for this machine. It is important to determine correct position and direction for `table_attach_point` and `head_attach_point`.*

You can change the value of the `I`, `J` and `K` vectors to create `*.mtd` machines with non-standard kinematics.

The following examples show DMG and Okuma machine tools:

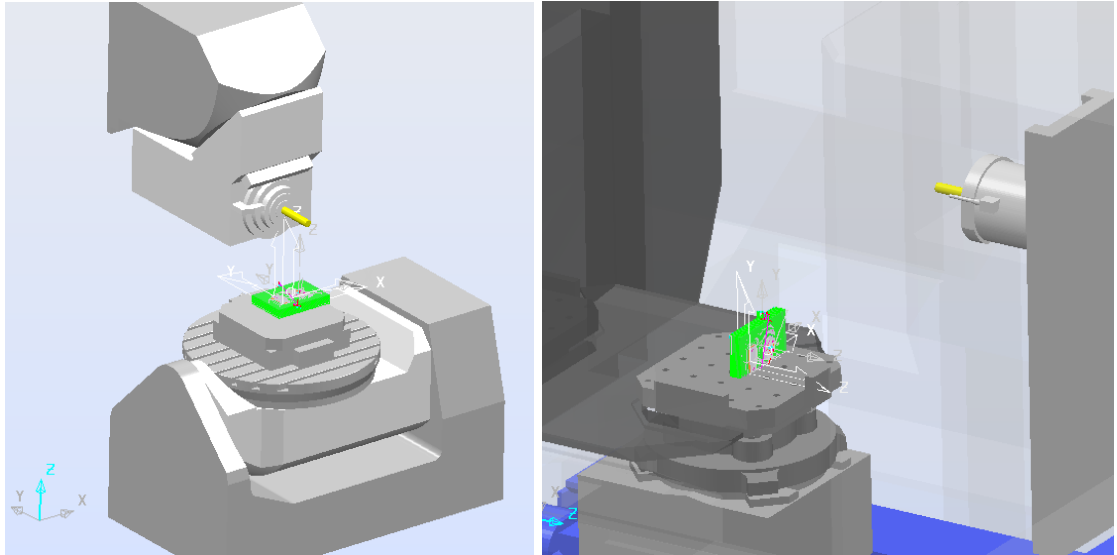

Do not use capital letters in the `attach_point` description.

```
<table_attach_point PART="Table" X="0" Y="0" Z="0"/>
<head_attach_point PART="Head" X="0" Y="220" Z="430" I="1" J="0" K="0"/>
```



```
<table_attach_point PART="table" X="0" Y="0" Z="0"/>
<head_attach_point PART="head" X="0" Y="220" Z="430" I="1" J="0" K="0"/>
```



Tool change simulation is available from PowerMill 2015 R2. This is an important function for difficult projects.

## Creating the tool-change point

```
<tool_change>
  <tool_change_pre_moves>
    MOVETO X0 Y350 Z300 A0 C0
  </tool_change_pre_moves>
  <tool_change_post_moves>
    WAIT 200
    MOVETO X0 Y350
    WAIT 200
    MOVETO Z300
  </tool_change_post_moves>
  <tool_change_moves>
    MOVETO X0 Y350
    WAIT 200
    TOOLCHANGE
    MOVETO X0
    WAIT 200
  </tool_change_moves>
</tool_change>
```

Where:

- `MOVETO X0 Y350 Z300 A0 C0` describes the position and direction of the point of tool changing.
- `WAIT 200` indicates the delay in milliseconds

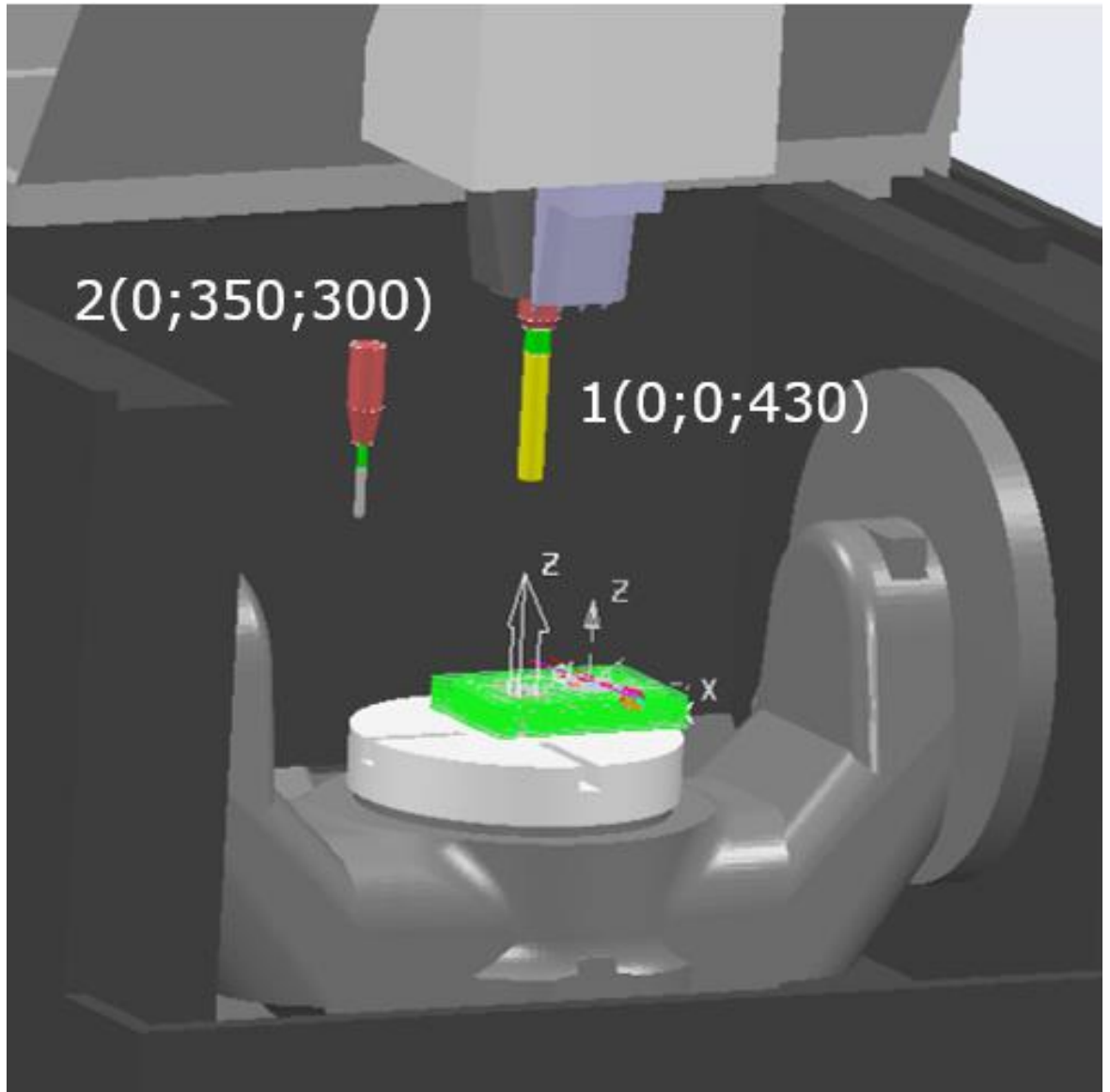

Point number one indicates the position of the `head_attach_point`.

Point number two indicates the position of the `tool_change`.

The Tool\_change on the next picture (in XML language) is:

```
26
27 <table_attach_point PART="table" X="0" Y="0" Z="0"/>
28 <head_attach_point PART="head" X="0" Y="220" Z="430" I="0" J="0" K="1"/>
29
30 <tool_change>
31   <tool_change_pre_moves>
32     MOVETO X0 Y350 Z300 A0 C0
33   </tool_change_pre_moves>
34   <tool_change_post_moves>
35     WAIT 200
36     MOVETO X0 Y350
37     WAIT 200
38     MOVETO Z300
39   </tool_change_post_moves>
40   <tool_change_moves>
41     MOVETO X0 Y350
42     WAIT 200
43     TOOLCHANGE
44     MOVETO X0
45     WAIT 200
46   </tool_change_moves>
47 </tool_change>
```

The tool change command is: MOVETO X735 Y0 Z500 B-90 C270.

```
<tool_change>
  <tool_change_pre_moves>
    MOVETO X735 Y0 Z500 B-90 C270
  </tool_change_pre_moves>
  <tool_change_post_moves>
    WAIT 200
    MOVETO X735 Y0
    WAIT 200
    MOVETO Z500
  </tool_change_post_moves>
  <tool_change_moves>
    MOVETO X750 Y0
    WAIT 200
    TOOLCHANGE
    MOVETO X745
    WAIT 200
  </tool_change_moves>
</tool_change>
```

Before changing the tool:

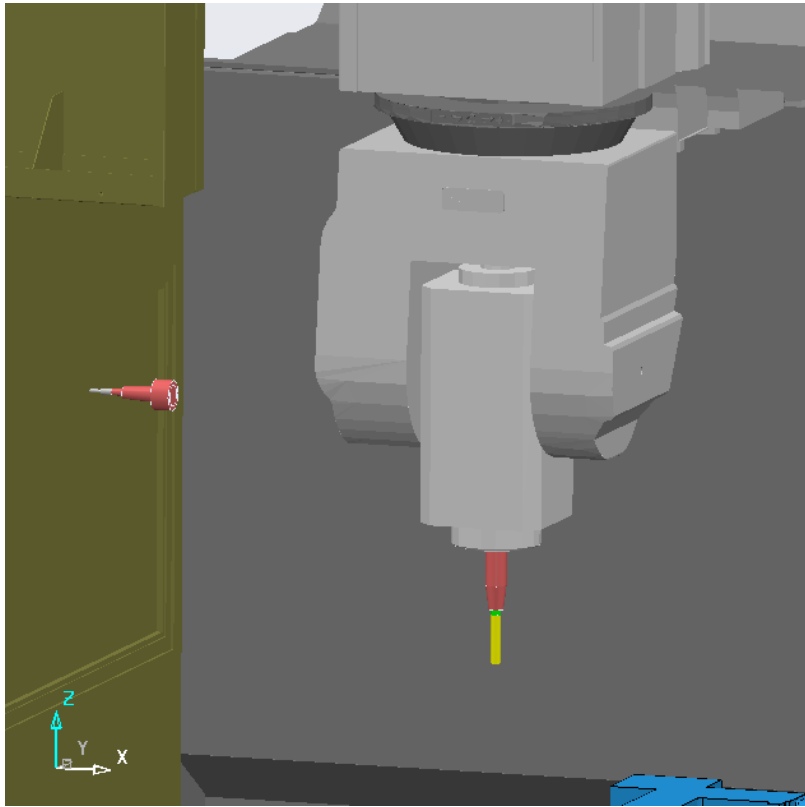

At the time of changing the tool:

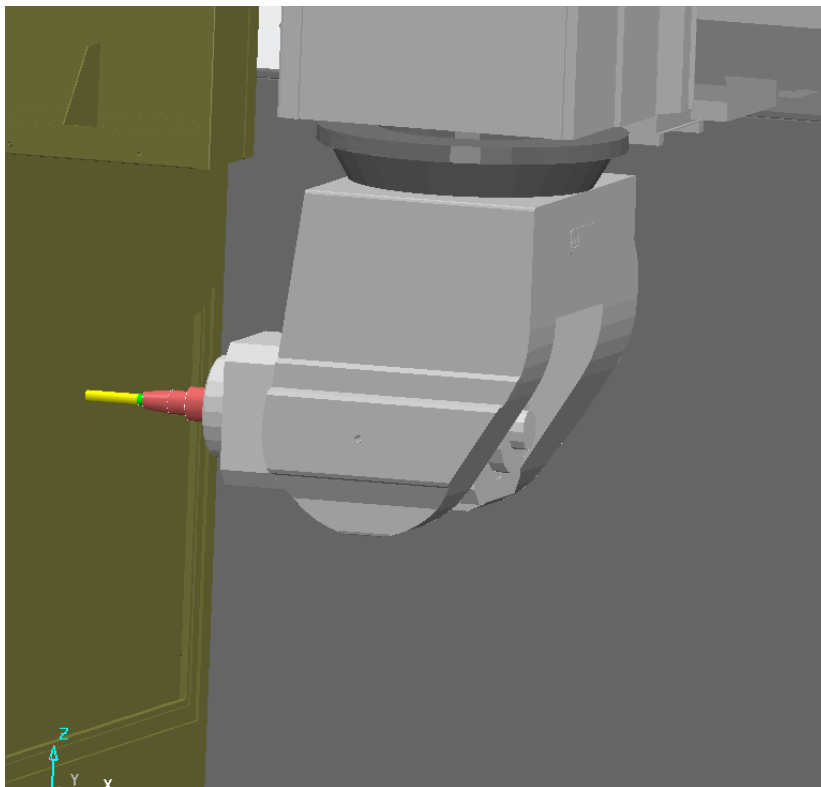

# Description of static elements

The next step is to define the machine parts. First, define which parts of the machine tool are static, such as the **Base**, **Housing** and the **Controller**. They need to be defined in order to visually represent the machine tool.

All static parts of the machine should be described in the block `The static bits`.

```
29
30 <!-- ===== The static bits ===== -->
31 <machine_part>
32 <model_list OPACITY="10">
33 <dmf_file>
34 <path FILE="Hermle_C12_SRT320/housing.dmf" />
35 <rgb R="250" G="250" B="250"/>
36 </dmf_file>
37 <dmf_file>
38 <path FILE="Hermle_C12_SRT320/door.dmf" />
39 <rgb R="240" G="240" B="240"/>
40 </dmf_file>
41 <dmf_file>
42 <path FILE="Hermle_C12_SRT320/handle.dmf" />
43 <rgb R="255" G="0" B="0"/>
44 </dmf_file>
45 </model_list>
46 </machine_part>
47 <machine_part>
48 <model_list>
49 <dmf_file>
50 <path FILE="Hermle_C12_SRT320/logo_1.dmf" />
51 <rgb R="255" G="0" B="0"/>
52 </dmf_file>
53 </model_list>
54 </machine_part>
55 <machine_part>
56 <model_list>
57 <dmf_file>
58 <path FILE="Hermle_C12_SRT320/logo_2.dmf" />
59 <rgb R="200" G="200" B="200"/>
60 </dmf_file>
61 </model_list>
62 </machine_part>
63 <machine_part>
64 <model_list>
65 <dmf_file>
66 <path FILE="Hermle_C12_SRT320/base.dmf" />
67 <rgb R="80" G="80" B="80"/>
68 </dmf_file>
69 </model_list>
70 </machine_part>
```

Any part of the machine is loaded into \*.mtd \* using the following commands:

```
<machine_part>
<model_list>
<dmt_file>
<path FILE="machine/part_1.dmt"/>
<rgb R="0" G="140" B="255"/>
</dmt_file>
</model_list>
</machine_part>
```

Where:

- `<path FILE="machine/part_1.dmt"/>` . This line gives the location of the machine part.
- `<rgb R="0" G="140" B="255"/>` . This line gives the colour of machine part.

A colour in the R (red) G (green) B (blue) colour model is described by indicating how much of each of the red, green, and blue is included. The colour is expressed as an RGB triplet (r,g,b), each component of which can vary from zero to a defined maximum value. If all the components are at zero the result is black; if all are at maximum (255), the result is the brightest representable white.

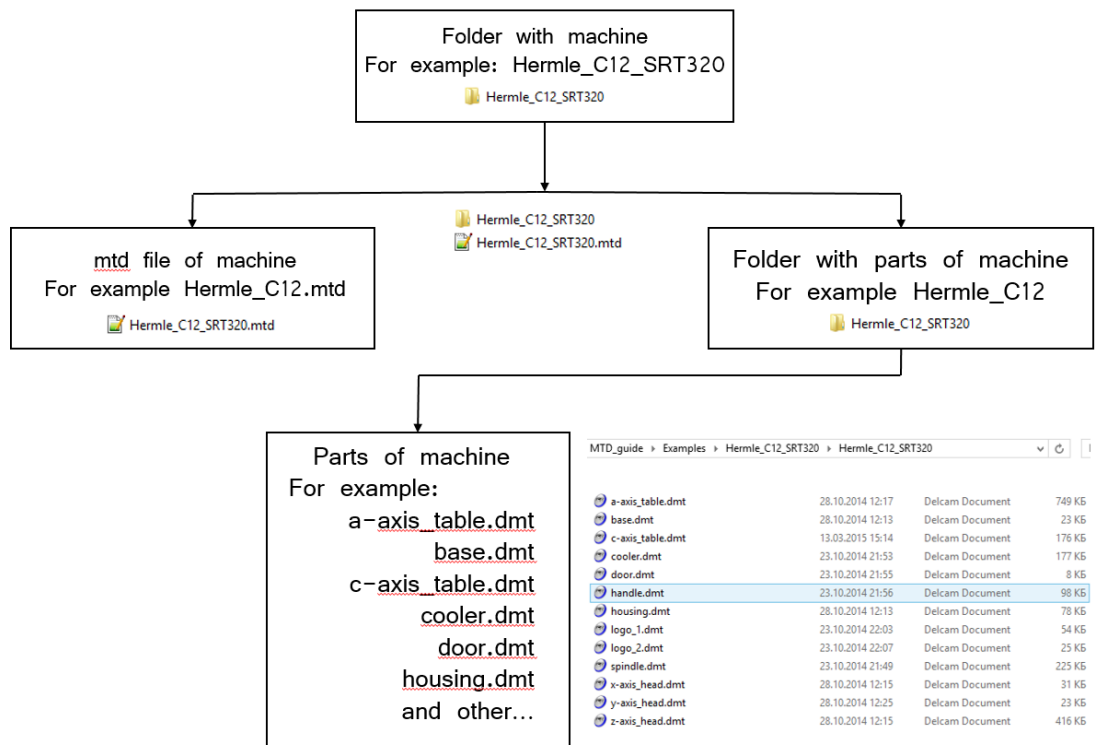

You can include all static parts on one `<machine_part>`:

```
<machine_part>
<model_list>
<dmt_file>
<path FILE="machine/part_1.dmt"/>
<rgb R="0" G="140" B="255"/>
</dmt_file>
<dmt_file>
<path FILE="machine/part_2.dmt"/>
<rgb R="0" G="0" B="0"/>
</dmt_file>
```

```

<dmt_file>
<path FILE="machine/part_3.dmt"/>
<rgb R="0" G="140" B="255"/>
</dmt_file>
<dmt_file>
<path FILE="machine/part_4.dmt"/>
<rgb R="0" G="140" B="255"/>
</dmt_file>
<dmt_file>
<path FILE="machine/part_5.dmt"/>
<rgb R="0" G="140" B="255"/>
</dmt_file>
</model_list>
</machine_part>

```

Alternatively, you can use for each static element a personal

```

<machine_part>:
<machine_part>
<model_list>
<dmt_file>
<path FILE="machine/part_1.dmt"/>
<rgb R="0" G="140" B="255"/>
</dmt_file>
</model_list>
</machine_part>
<machine_part>
<model_list>
<dmt_file>
<path FILE="machine/part_2.dmt"/>
<rgb R="0" G="0" B="0"/>
</dmt_file>
</model_list>
</machine_part>
<machine_part>
<model_list>
<dmt_file>
<path FILE="machine/base.dmt"/>
<rgb R="60" G="80" B="255"/>
</dmt_file>
</model_list>
</machine_part>

```



*Use the most important static part at the end of static block. For example: base, table, pallet etc.*

Below is an example of the full text of the static block:

```

<!-- ===== The static bits ===== -->
<machine_part>
<model_list OPACITY="10">
<dmt_file>
<path FILE="Hermle_C12_SRT320/housing.dmt"/>
<rgb R="250" G="250" B="250"/>
</dmt_file>
<dmt_file>
<path FILE="Hermle_C12_SRT320/door.dmt"/>
<rgb R="240" G="240" B="240"/>
</dmt_file>
<dmt_file>
<path FILE="Hermle_C12_SRT320/handle.dmt"/>
<rgb R="255" G="0" B="0"/>
</dmt_file>
</model_list>

```

```

</machine_part>
<machine_part>
<model_list>
<dmt_file>
<path FILE="Hermle_C12_SRT320/logo_1.dmt" />
<rgb R="255" G="0" B="0"/>
</dmt_file>
</model_list>
</machine_part>
<machine_part>
<model_list>
<dmt_file>
<path FILE="Hermle_C12_SRT320/logo_2.dmt" />
<rgb R="200" G="200" B="200"/>
</dmt_file>
</model_list>
</machine_part>
<machine_part>
<model_list>
<dmt_file>
<path FILE="Hermle_C12_SRT320/base.dmt" />
<rgb R="80" G="80" B="80"/>
</dmt_file>
</model_list>
</machine_part>

```

**Additional commands for static block:**

- Transparency or opacity of machine parts (if necessary).
- Collision detection.



`<model_list OPACITY="10">` (giving 90% transparency):

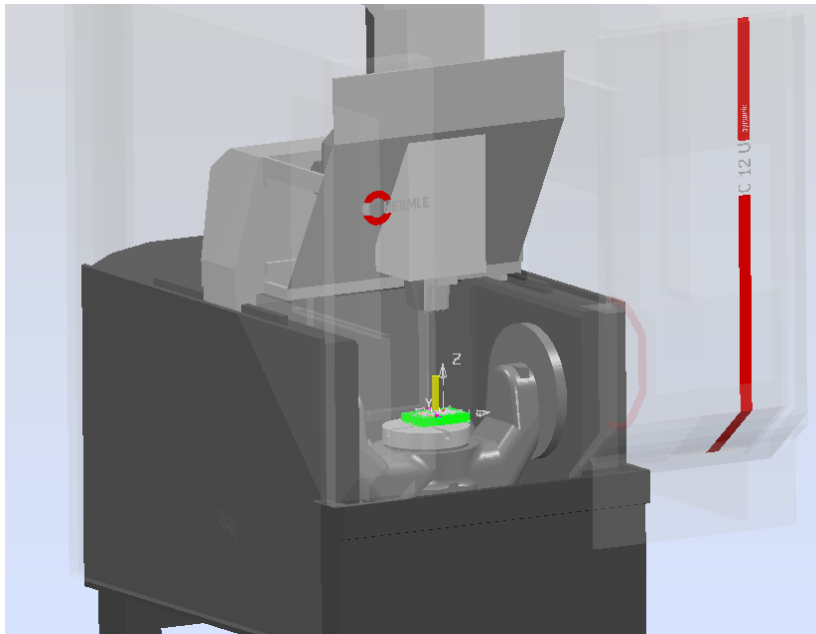

==== The static bits ==== -->

```
<machine_part>
```

```
  <model_list OPACITY="10">
```

```
    <dmt_file>
```

```
      <path FILE="Hermle_C12_SRT320/housing.dmt" />
```

```
      <rgb R="250" G="250" B="250"/>
```

`<model_list OPACITY="100">` (giving 0% transparency):

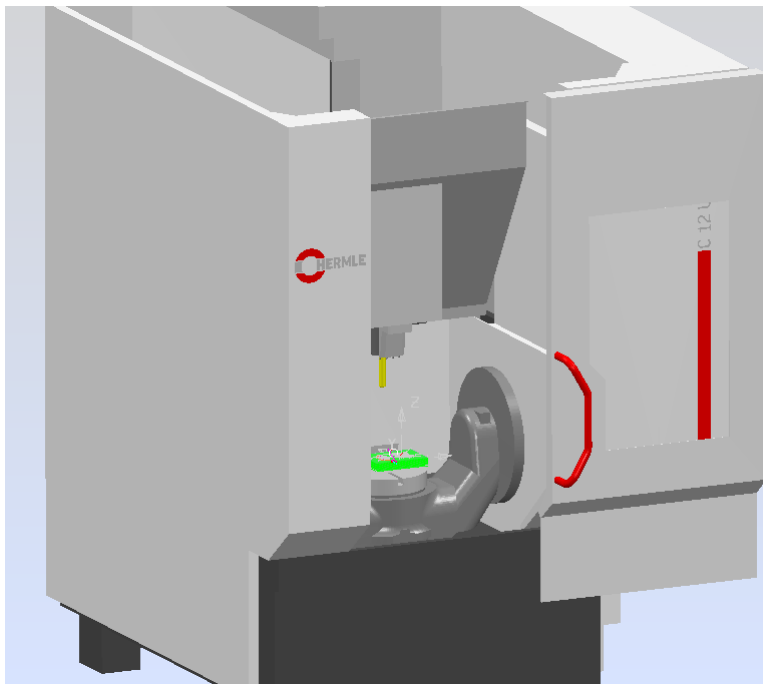

```

<!-- ===== The static bits ===== -->
    <machine_part>
        <model_list OPACITY="100">
            <dmt_file>
                <path FILE="Hermle_C12_SRT320/housing.dmt" />
                <rgb R="250" G="250" B="250"/>
            </dmt_file>
        </model_list>
    </machine_part>

```

All machine parts, that are included in such `<model_list OPACITY="10">` have the same transparency. If you want use different transparency then use different `<model_list OPACITY="XX">`.

## Collision detection

The static parts are used for detailed visualization of the machine and for determining the correct workspace for simulation. Simulating the machine movements is important for the detection of collisions for all types of machines tools (3-axis, 4-axis, 5-axis and others).



*PowerMill does not detect collisions with static elements (it is dangerous, especially for the five-axis machine tools).*

See the next example with **CMS\_Antares Head-head** machine (the table part is not moveable).

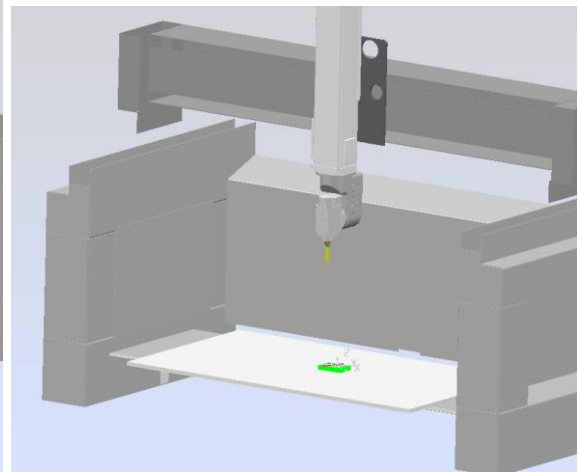
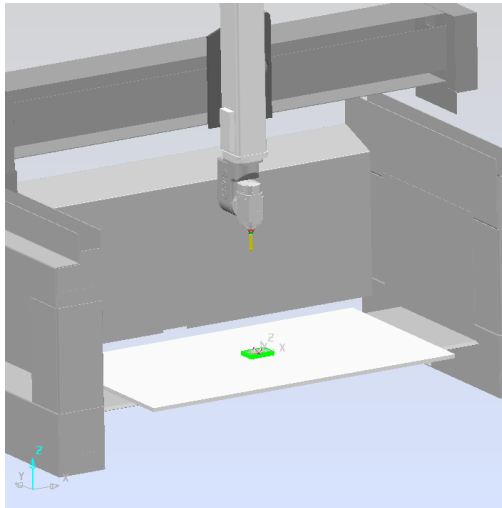

The following shows the static block text, where `pallet.dmt` is the upper surface of the table.

```

<!-- Static bits -->
  <machine_part>
    <model_list>
      <dmt_file>
        <path FILE="CMS_Antares/Carter.dmt" />
        <rgb R="200" G="200" B="200" />
      </dmt_file>
      <dmt_file>
        <path FILE="CMS_Antares/pallet.dmt" />
        <rgb R="255" G="255" B="255" />
      </dmt_file>
    </model_list>
  </machine_part>
<machine_part NAME="table" />
<!-- The head -->

```

Using **Machine Tool Position** in PowerMill enables you to change the Z axis position. If you move the Z axis down (simulation of collision `Z-axis_head` with a table), the collision is not detected in PowerMill.

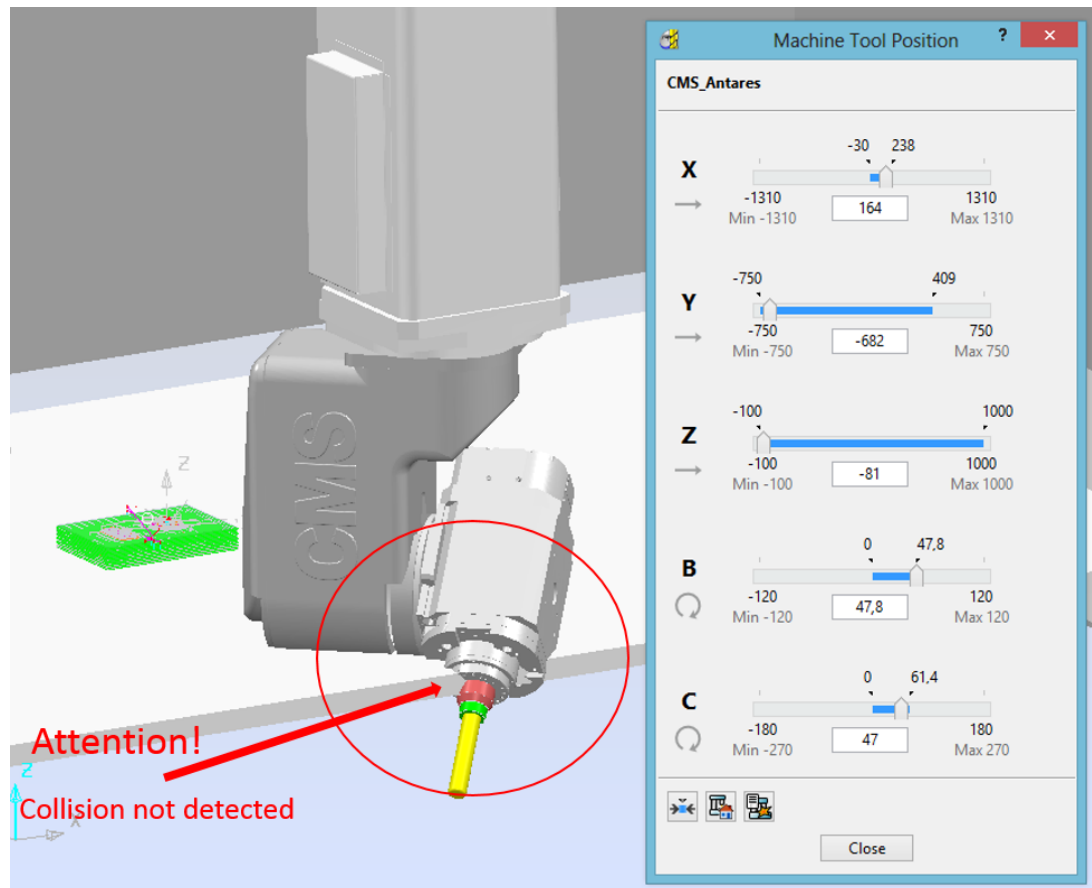

You must change the description of `pallet.dmt`.

```
<machine_part NAME="pallet">
<model_list>
<dmt_file>
<path FILE="CMS_Antares/pallet.dmt" />
<rgb R="255" G="255" B="255" />
</dmt_file>
</model_list>
</machine_part>
```

When the `NAME` parameter is added to the `<machine_part>` description, PowerMill detects the collision correctly:

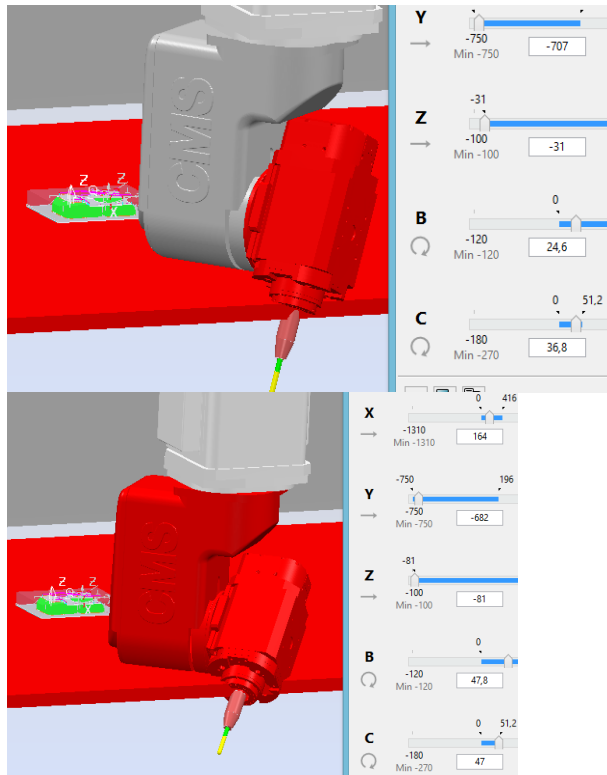

When a collision occurs, the colliding parts of machine are coloured and a warning message is displayed:

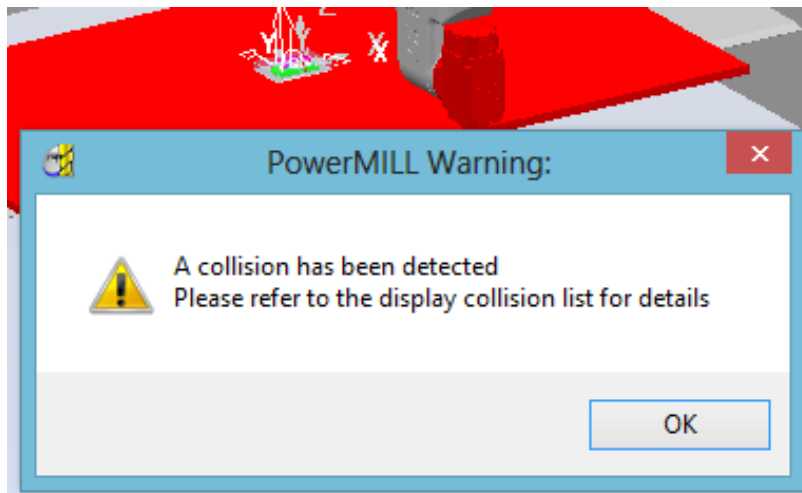

All static parts of machine, which are located at working area, must be described as above.

# Description of the movable elements

This topic looks at the main types of machine tools (kinematics and structure). Every \*.mtd that you create differs, depending on the configuration of the machine tool. This is important for 5 axis machine tools, where the axes are defined in the \*.mtd as head or table entities. For 5 axis machines there will be 3 different configurations:

- Head-Head.
- Head-Table.
- Table-Table (Trunion).

Below are three examples showing how the different configurations can be split into head and table components. Machine tools are not limited to these configurations; they are given as a guide:

## Head-Head

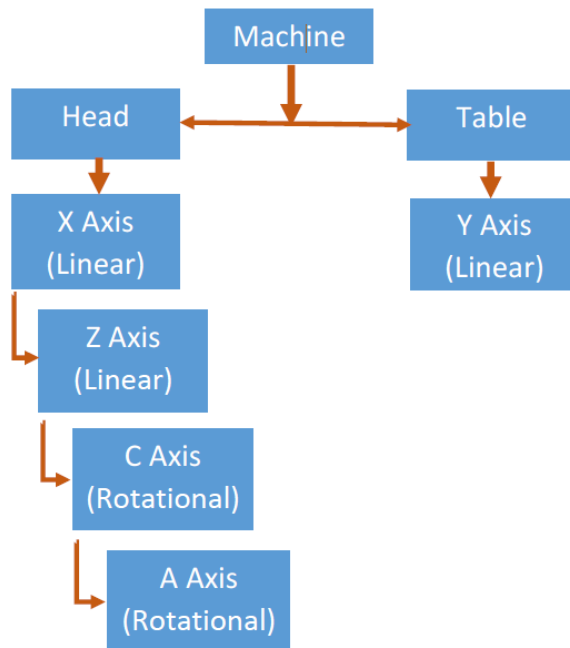

Example of **Head-Head – Zayer FPC-AR**:

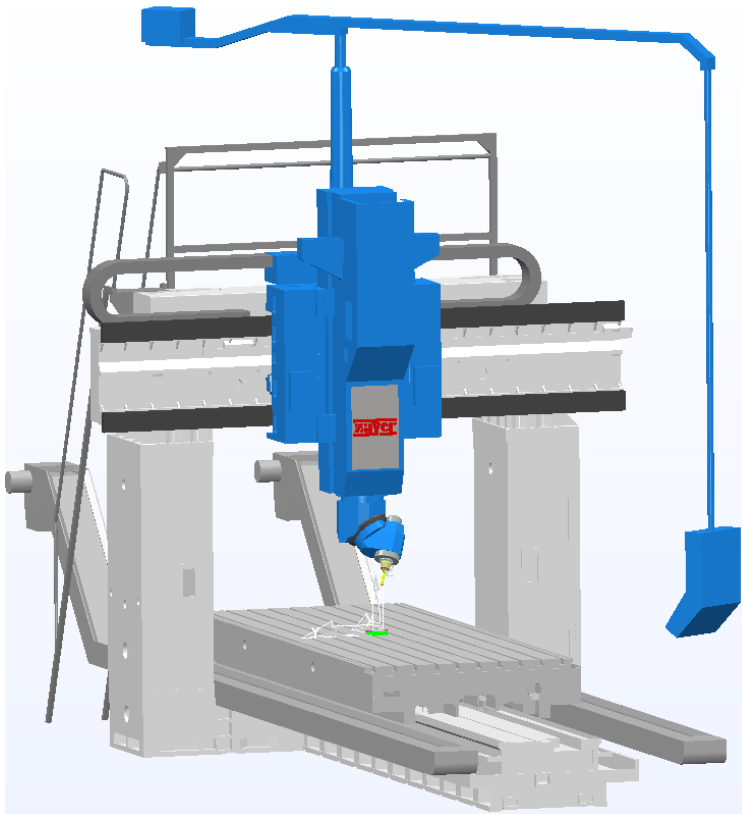

# Head-Table

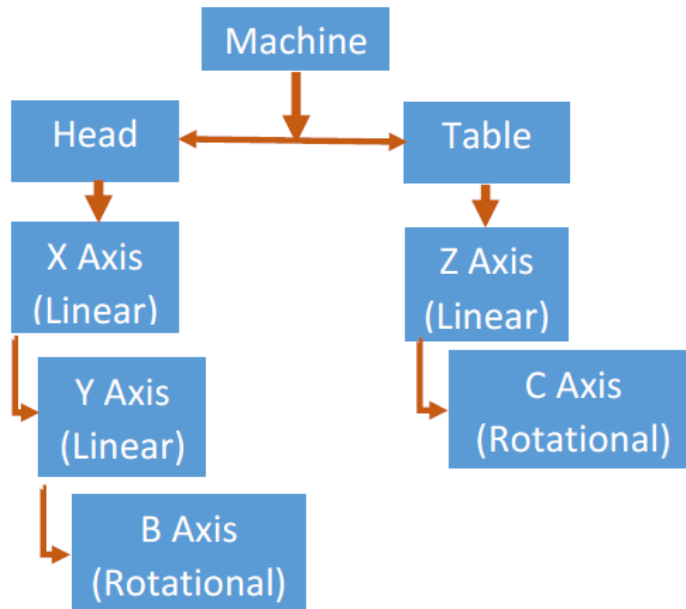

Example of **Head-Table – DMG DMU80 monoBLOCK:**

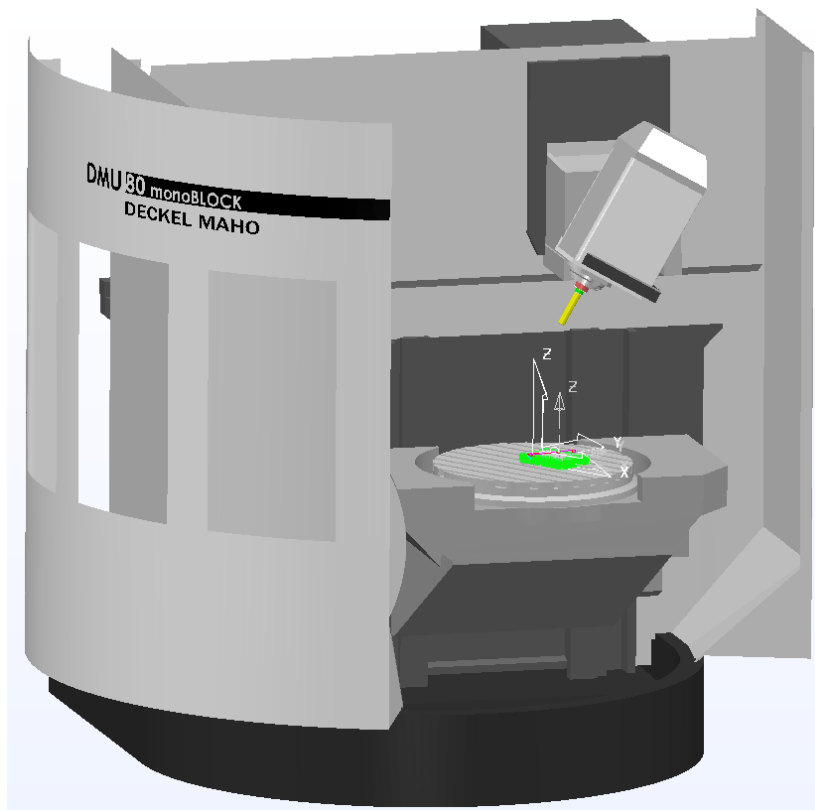

## Table-Table (Trunion)

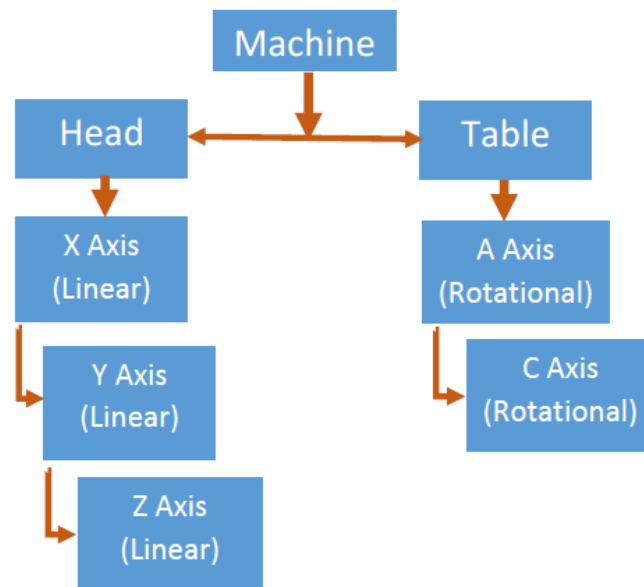

Example of **Table-Table Hermle\_C12\_SRT320** (Table 320):

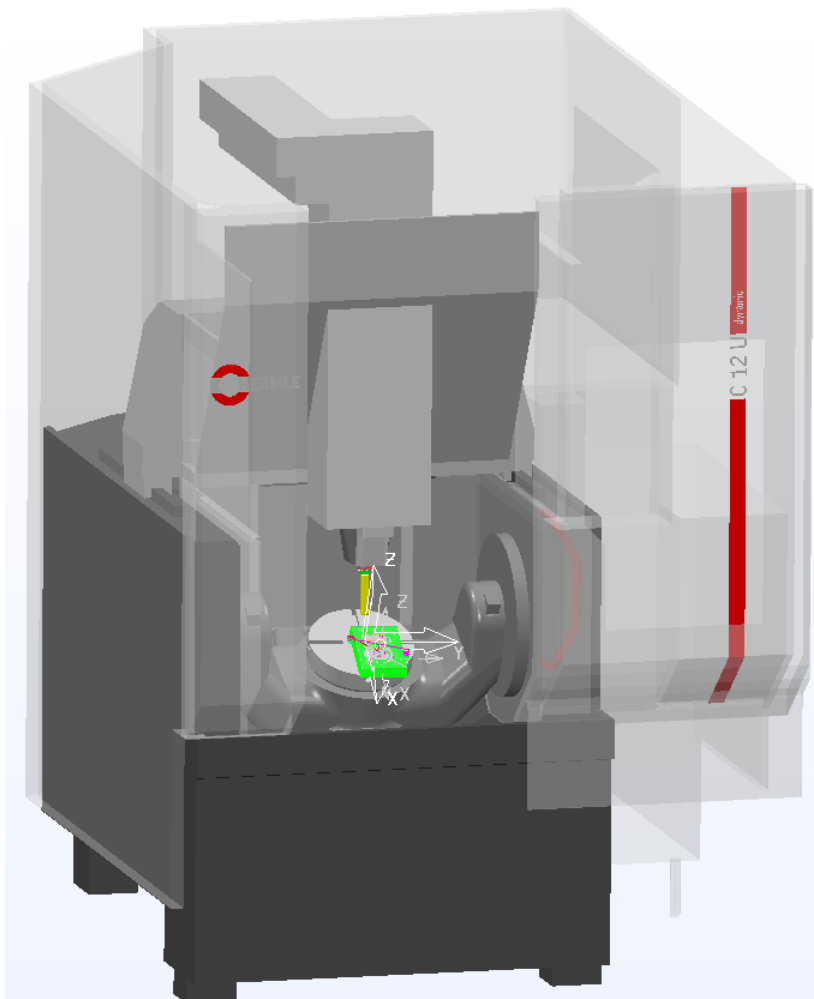

Now you can create the `<machine_part>` definitions. There are two `<machine_part>` definitions: one for the head of the machine and one for the table. This example defines a machine tool with a Table-Table configuration.

As a result of this configuration, the Head machine part consists of elements making up the X, Y and Z axial components. The Table machine part consists of elements making up the A and C axial components. See previous picture (**Hermle\_C12\_SRT320**).

Let us consider hierarchy of machine movements:

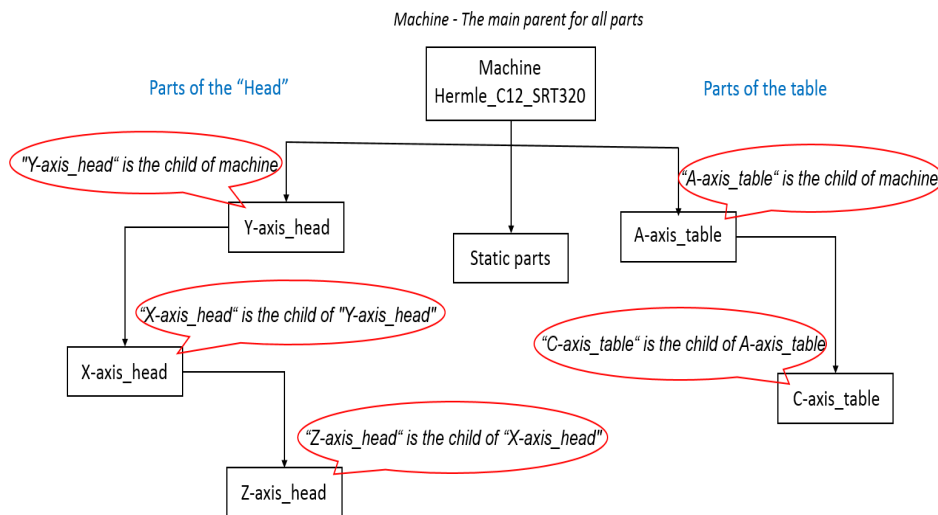

This example begins with the Y axis. The component model that makes up the Y axis acts as the parent component upon which the remaining axial components for X and Z are attached. You must give each axial component a definition:

`<axis>`: Used to define an axis. Within this we need to give an axis a name, a value, limits and a movement vector.

```

<axis>
  <control_info ADDRESS="Y" VALUE="220" HOME="0" MIN="-220" MAX="220" />
  <simple_linear I="0" J="1" K="0" />
</axis>
  
```

Use the following commands to define the axis:

- `control_info ADDRESS` — This defines the axis name as X, Y, Z, A, B, C or any other names.
- `VALUE` — This is the value that is shown in the Machine Information Dialog when the machine is in its home position.
- `MIN` and `MAX` — These are the limits that the axis can travel to.
- `PRIORITY` — Defines the priority of movements, respectively "HIGH", "MEDIUM" and "LOW".
- `HOME` — Assigns a new correct position of "home position" (if `VALUE` is wrong).
- `simple_linear` — Defines how an axis moves if it is only for linear movement using vectors I, J or K.
- `simple_rotary` — Defines how an axis moves only for rotational movement. You must define the centre of rotation and a vector to define the direction of rotation.

How they all fit together in our Hermle machine tool example:

```

===== The head ===== -->
<machine_part>
  <axis>
    <control_info ADDRESS="Y" VALUE="220" HOME="0" MIN="-220" MAX="220" />
    <simple_linear I="0" J="1" K="0" />
  </axis>
  <model_list>
    <dmt_file>
      <path FILE="Hermle_C12_SRT320/y-axis_head.dmt" />
      <rgb R="185" G="185" B="185"/>
    </dmt_file>
  </model_list>
  <machine_part>
    <axis>
      <control_info ADDRESS="X" VALUE="0" MIN="-175" MAX="175"/>
      <simple_linear I="1" J="0" K="0" />
    </axis>
    <model_list>
      <dmt_file>
        <path FILE="Hermle_C12_SRT320/x-axis_head.dmt" />
        <rgb R="100" G="100" B="100"/>
      </dmt_file>
    </model_list>
    <machine_part>
      <axis>
        <control_info ADDRESS="Z" VALUE="430" MIN="100" MAX="430" />
        <simple_linear I="0" J="0" K="1" />
      </axis>
      <model_list>
        <dmt_file>
          <path FILE="Hermle_C12_SRT320/z-axis_head.dmt" />
          <rgb R="215" G="215" B="215"/>
        </dmt_file>
        <dmt_file>
          <path FILE="Hermle_C12_SRT320/cooler.dmt" />
          <rgb R="200" G="200" B="200"/>
        </dmt_file>
        <dmt_file>
          <path FILE="Hermle_C12_SRT320/spindle.dmt" />
          <rgb R="120" G="120" B="120"/>
        </dmt_file>
      </model_list>
      <machine_part NAME="head" />
    </machine_part>
  </machine_part>
</machine_part>

```

his Hermle machine tool has:

*Centre of table:* X=0; Y=0; Z=0.

*Centre of spindle:* X=0; Y=220; Z=430.

Below is a text of description of the Y-axis:

```

<machine_part>
  <axis>
    <control_info ADDRESS="Y" VALUE="220" HOME="0" MIN="-220"
MAX="220" />
    <simple_linear I="0" J="1" K="0" />
  </axis>
  <model_list>
    <dmt_file>
      <path FILE="Hermle_C12_SRT320/y-axis_head.dmt" />
      <rgb R="185" G="185" B="185"/>
    </dmt_file>
  </model_list>

```

Use the following commands:

- `<machine_part>` — Create (open) the part of the \*.mtd.
- `<axis>` and `</axis>` — Open and close the description of the axis.
- `<control_info ADDRESS="Y"` — Create a Y axis. "Y" is the name of the axis.
- `VALUE="220"` — A command that states that the current position of the Y axis is 220 mm (data from PoweShape).
- `HOME="0"` — A command that returns the Y-axis to the "0" position (centre of table); If you use `HOME="-100"`, then the position of Y-axis is Y=-100. The command `HOME` is used to give the correct position for all axial parts of machine (origin position).
- `MIN="-220"` and `MAX="220"` — Minimum and maximum limits of axis movement.
- `<simple_linear ... />` — Create the linear axis.
- `I="0" J="1" K="0" />` — Direction of movement; if `I="1" J="0" K="0"` then motion occurs along the X axis, if `I="0" J="1" K="0"` then motion takes along Y axis, if `I="0" J="0" K="1"` then motion occurs along the Z-axis.
- `<model_list>` and `</model_list>` — Open and close the line of model.
- `<dmt_file>` and `</dmt_file>` — Open and close the file.
- `<path FILE="Hermle_C12_SRT320/y-axis_head.dmt" />` — The address where the file is located.
- `<rgb R="185" G="185" B="185"/>` — The colour scheme of the machine part: R-red, G-green, B-blue.
- `</machine_part>` close the part of mtd.

Additional commands, that describe the rotary parts of the machine.

```
<axis>
  <control_info ADDRESS="A" MIN="-115" MAX="115" />
  <simple_rotary X="0" Y="0" Z="80" I="-1" J="0" K="0" />
</axis>
```

Such commands as:

- `<simple_rotary />` — Create the rotary axis.
- `X="0" Y="0" Z="80"` — The coordinates of the centre of rotation relative to the global coordinate system (`table_attach_point`).
- `I="-1" J="0" K="0"` — Direction of movement; if `I="1" J="0" K="0"` then rotation occurs around the X axis, if `I="0" J="1" K="0"` then rotation occurs around the Y axis, if `I="0" J="0" K="1"` then rotation occurs around the Z axis.

Minus indicates the direction of rotation, if  $I=-1$   $J=0$   $K=0$  then rotation occurs around the X axis in the negative direction.



Full details about a coordinates and direction of rotation are given in a later section.

Each machine axis can contain several parts of the machine, for example `z-axis_head`. Traditionally Z-axis included such parts as: Z-axis, the spindle, cooling equipment and the logo:

```
<machine_part>
  <axis>
    <control_info ADDRESS="Z" VALUE="430" MIN="100" MAX="430" />
    <simple_linear I="0" J="0" K="1" />
  </axis>
  <model_list>
    <dmt_file>
      <path FILE="Hermle_C12_SRT320/z-axis_head.dmt" />
      <rgb R="215" G="215" B="215"/>
    </dmt_file>
    <dmt_file>
      <path FILE="Hermle_C12_SRT320/cooler.dmt" />
      <rgb R="200" G="200" B="200"/>
    </dmt_file>
    <dmt_file>
      <path FILE="Hermle_C12_SRT320/spindle.dmt" />
      <rgb R="120" G="120" B="120"/>
    </dmt_file>
  </model_list>
  <machine_part NAME="head" />
</machine_part>
```

You can use different colours for each part, but can't use different `OPACITY`. `OPACITY` are applied for all parts in one `<model_list>`.



`VALUE` does not always need to be presented in origin position. You can use the command `HOME` to define this position.

The most important parameter for each machine is distance between the upper surface table and the spindle nose. This distance is called Spindle Nose to Table. These values define the limits of the Z-axis:  $Z_{min}$  and  **$Z_{max}$** , relative the centre of the table ( $X=0$ ;  $Y=0$ ;  $Z=0$ ).

For example, specification **Haas VF-2**:

TRAVELS	S.A.E.	METRIC
X Axis	30 "	762 mm
Y Axis	16 "	406 mm
Z Axis	20 "	508 mm
Spindle Nose to Table (~ max)	24 "	610 mm
Spindle Nose to Table (~ min)	4 "	102 mm

The information about the Spindle Nose to Table can be given by drawings stating the travel range of each axis. Below is an example of **Okuma\_Millac\_33TU**.

### Travel range of each axis

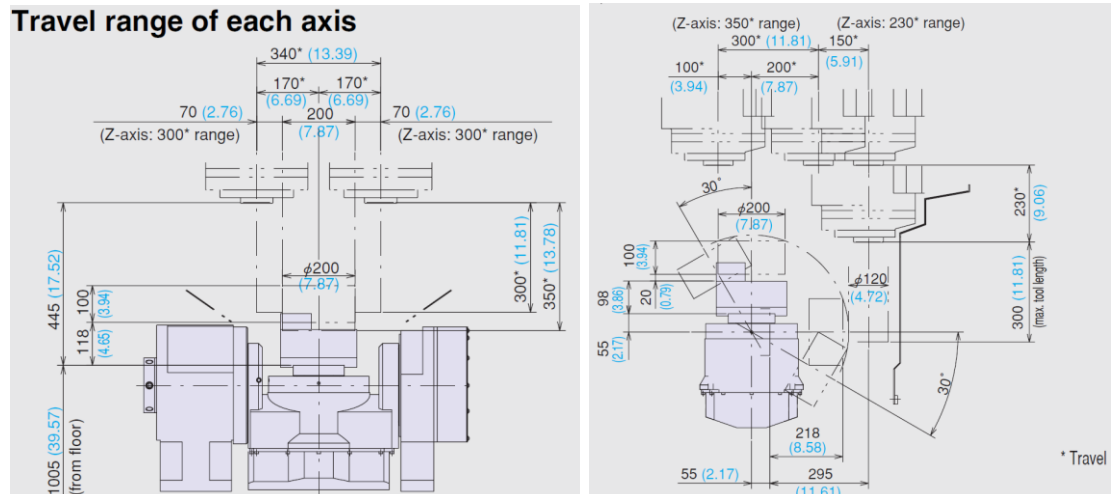

The example above ([Z-axis\\_head](#) on the previous page) shows a list of three models that are used to make up the Z-axis of the machine tool: [z-axis\\_head](#), [cooler](#), [spindle](#). The remaining components are axial.



*You must associate axis components and controls to the primary `machine_part` object.*

Following is an example of the machine tool [Hermle\\_C12\\_SRT320](#). The Y-axis is the primary (or parent) component for the head assembly. Therefore, before you close the Y-axis `machine_part`, you must open a new `machine_part` for each new axis component and continue until all head components making up the head of the machine are defined, excluding specific details for each axis.



```

                                <path
FILE="Hermle_C12_SRT320/z-axis_head.dmt" />
                                <rgb R="215" G="215"
B="215"/>
                                </dmt_file>
                                <dmt_file>
                                <path
FILE="Hermle_C12_SRT320/cooler.dmt" />
                                <rgb R="200" G="200"
B="200"/>
                                </dmt_file>
                                <dmt_file>
                                <path
FILE="Hermle_C12_SRT320/spindle.dmt" />
                                <rgb R="120" G="120"
B="120"/>
                                </dmt_file>
                                </model_list>
                                <machine_part NAME="head" />
                                </machine_part>
                                </machine_part>
</machine_part>

```

At the end of the block "The head" you can use: `<machine_part NAME="head" />` This line defines the parts of the machine (all parts previously described: `y-axis_head.dmt`; `x-axis_head.dmt`; `z-axis_head.dmt`; `cooler.dmt`; `spindle.dmt`) as "The head" and connects them with the solver of PowerMill and the PostProcessor.

---

# Direction of movement in The Head block



The positive movement of head-axes of the machine tool must match the positive directions of the axes of the global coordinate system.

According to this, the direction of vectors of movement ( $I$ ,  $J$  and  $K$ ) must have positive values. See below:

```
<axis>
  <control_info ADDRESS="Y" VALUE="220" HOME="0" MIN="-220" MAX="220" />
  <simple_linear I="0" J="1" K="0" />
</axis>
```

```
<axis>
  <control_info ADDRESS="X" VALUE="0" MIN="-175" MAX="175" />
  <simple_linear I="1" J="0" K="0" />
</axis>
```

```
<axis>
  <control_info ADDRESS="Z" VALUE="430" MIN="100" MAX="430" />
  <simple_linear I="0" J="0" K="1" />
</axis>
```



Check the direction of movement.

- 1 Open the machine tool (**Hermle**) in PowerMill.
- 2 Click Simulation tab > Draw panel > View > Model View.
- 3 Use the **Machine Tool Position** dialog to check the direction of movement is correct.

# Description of the movable elements: The table

Consider the movable elements of the table using an example **Hermle\_C12\_SRT320**. The rules of description are the same as for the head of the machine. In our **Hermle** machine tool example there are two axes components making up the table of the machine: `a-axis_table` and `c-axis_table`.

Below is a screenshot from the \*.mtd file:

```
<!-- ===== The table ===== -->
<machine_part>
  <axis>
    <control_info ADDRESS="A" MIN="-115" MAX="115" />
    <simple_rotary X="0" Y="0" Z="80" I="-1" J="0" K="0" />
  </axis>
  <model_list>
    <dmt_file>
      <path FILE="Hermle_C12_SRT320/a-axis_table.dmt" />
      <rgb R="140" G="140" B="140"/>
    </dmt_file>
  </model_list>
  <machine_part>
    <axis>
      <control_info ADDRESS="C" />
      <simple_rotary X="0" Y="0" Z="0" I="0" J="0" K="-1" />
    </axis>
    <model_list>
      <dmt_file>
        <path FILE="Hermle_C12_SRT320/c-axis_table.dmt" />
        <rgb R="200" G="200" B="200"/>
      </dmt_file>
    </model_list>
    <machine_part NAME="table" />
  </machine_part>
</machine_part>
</machine>
```

The `a-axis_table` is the primary (or parent) component for the table assembly. Therefore, before you close the `a-axis machine_part`, open a new `machine_part` for the `c-axis_table` component.

At the end of the block, "The table" you must use `<machine_part NAME="table"/>` this line defines the parts of the machine as "The Table" (all parts previously described: `a-axis_table.dmt` and `c-axis_table.dmt`) and connects them with the solver of PowerMill and PostProcessor.

This example uses the same definitions that were used with the machine head components. However, one difference highlighted is when you use a negative vector for the linear and rotary movement. In our case, `a-axis_head` and `c-axis_head` has negative direction.

As the table controls the a-axis, in order to simulate a positive a-axis movement from a toolpath, the table needs to move in the opposite direction. When you view the movement in the machine tool position dialog, all movements appear normal. However, the table moves in the opposite direction to the Workplane.

```

<axis>
  <control_info ADDRESS="A" MIN="-115" MAX="115" />
  <simple_rotary X="0" Y="0" Z="80" I="-1" J="0" K="0" />
</axis>

```

```

<axis>
  <control_info ADDRESS="C" />
  <simple_rotary X="0" Y="0" Z="0" I="0" J="0" K="-1" />
</axis>

```



*All axes (linear and rotary) included in "The Table" should move in opposite direction therefore need use minus for I, J or K vectors.*

The full text of the Table section is:

```

<!-- ===== The table ===== -->
<machine_part>
  <axis>
    <control_info ADDRESS="A" MIN="-115" MAX="115" />
    <simple_rotary X="0" Y="0" Z="80" I="-1" J="0" K="0" />
  </axis>
  <model_list>
    <dmt_file>
      <path FILE="Hermle_C12_SRT320/a-axis_table.dmt"
    />
    <rgb R="140" G="140" B="140"/>
  </dmt_file>
</model_list>
  <machine_part>
    <axis>
      <control_info ADDRESS="C" />
      <simple_rotary X="0" Y="0" Z="0" I="0" J="0"
K="-1" />
    </axis>
    <model_list>
      <dmt_file>
        <path FILE="Hermle_C12_SRT320/c-
axis_table.dmt" />
        <rgb R="200" G="200" B="200"/>
      </dmt_file>
    </model_list>
    <machine_part NAME="table" />
  </machine_part>
</machine_part>

```

# How to get XYZ values in PowerShape

When you create an \*.mtd file you need to know the exact location of the head attach point, rotation centre and axis values. We can do this in PowerShape by creating some simple geometry at any points of interest.

The following examples demonstrate how to identify the coordinates for different types of machine tool.

## Head-Head machine tools

Head-Head machine tool with collinear vectors of rotation (the axes of rotation are parallel to the axes of the global coordinate system).

For example, you need the centre of rotation for the A axis of the Rye machine tool.

The A axis component rotates around a centre point of this part so in PowerShape we isolate this part.

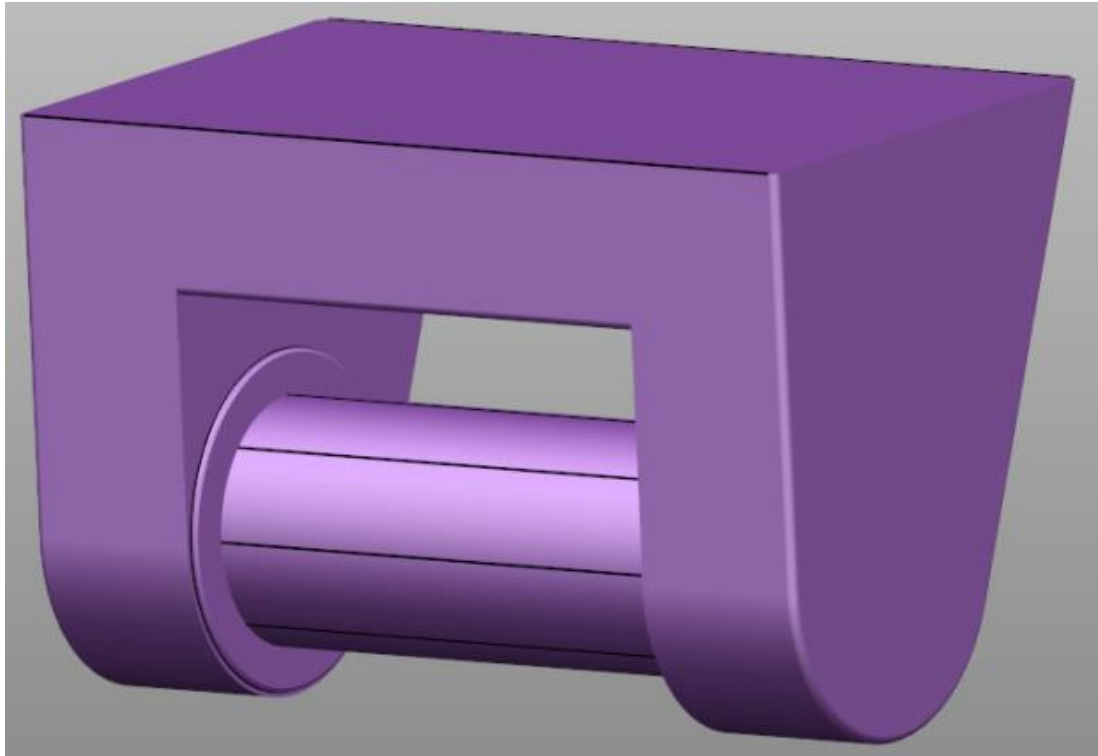

We then create some simple geometry (a line or an arc for example) where we can easily note the exact location for the centre of rotation:

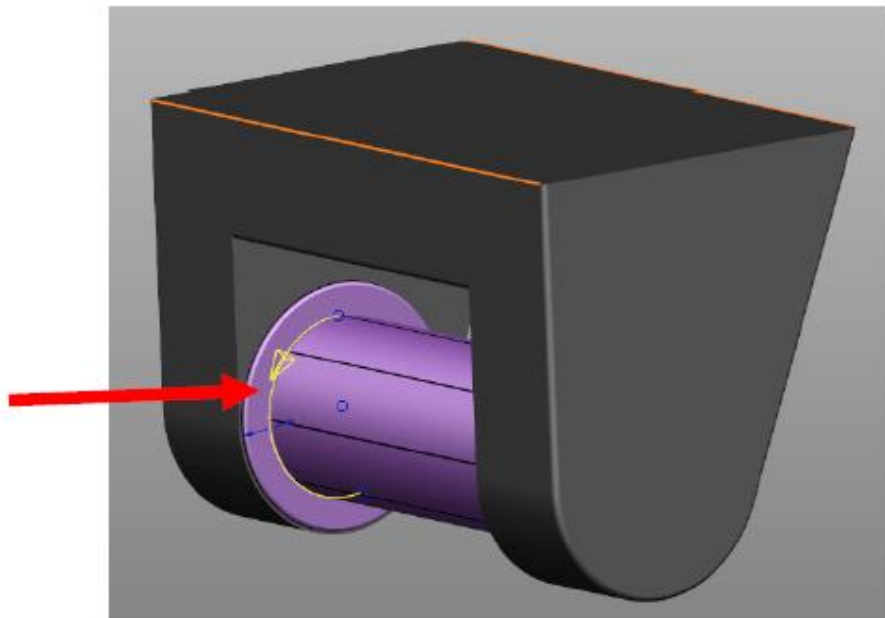

Editing the arc gives the centre point coordinates:

Name	4		
Radius	70.00196		
Span angle	191.2934		
Centre mark type	Dot		
Workspace	World		
Centre	-150	-51.80564	501.93202
Through	-150	-121.4671	495.03605



The global coordinate system (GCS) must be activated and be located in the centre of the table ( $X=0$   $Y=0$   $Z=0$ ). We can either change the X value to zero to move the arc to the centre of the cylinder or just ignore it and keep it zero in the \*.mtd

This results in:

```
<axis>
  <control_info ADDRESS="A" MIN="-110" MAX="110" />
  <simple_rotary X="0" Y="-51.80564" Z="501.93202" I="1" J="0" K="0" />
</axis>
<model_list>
  <dmt_file>
    <path FILE="rye/barrel_1.dmt" />
    <rgb R="245" G="245" B="245" />
  </dmt_file>
</model_list>
```

The rotation of A-axis\_head occurs around the X axis. Therefore the directions of the vectors are:  $I="1"$   $J="0"$   $K="0"$ .



Use positive value of vectors for movement parts of head. Use negative value of vectors for movement parts of table.

## Table-Table machine tools

Table-Table machine tool (Hermle\_C12\_SRT320) with collinear vectors of rotation (the axes of rotation are parallel to the axes of the global coordinate system).

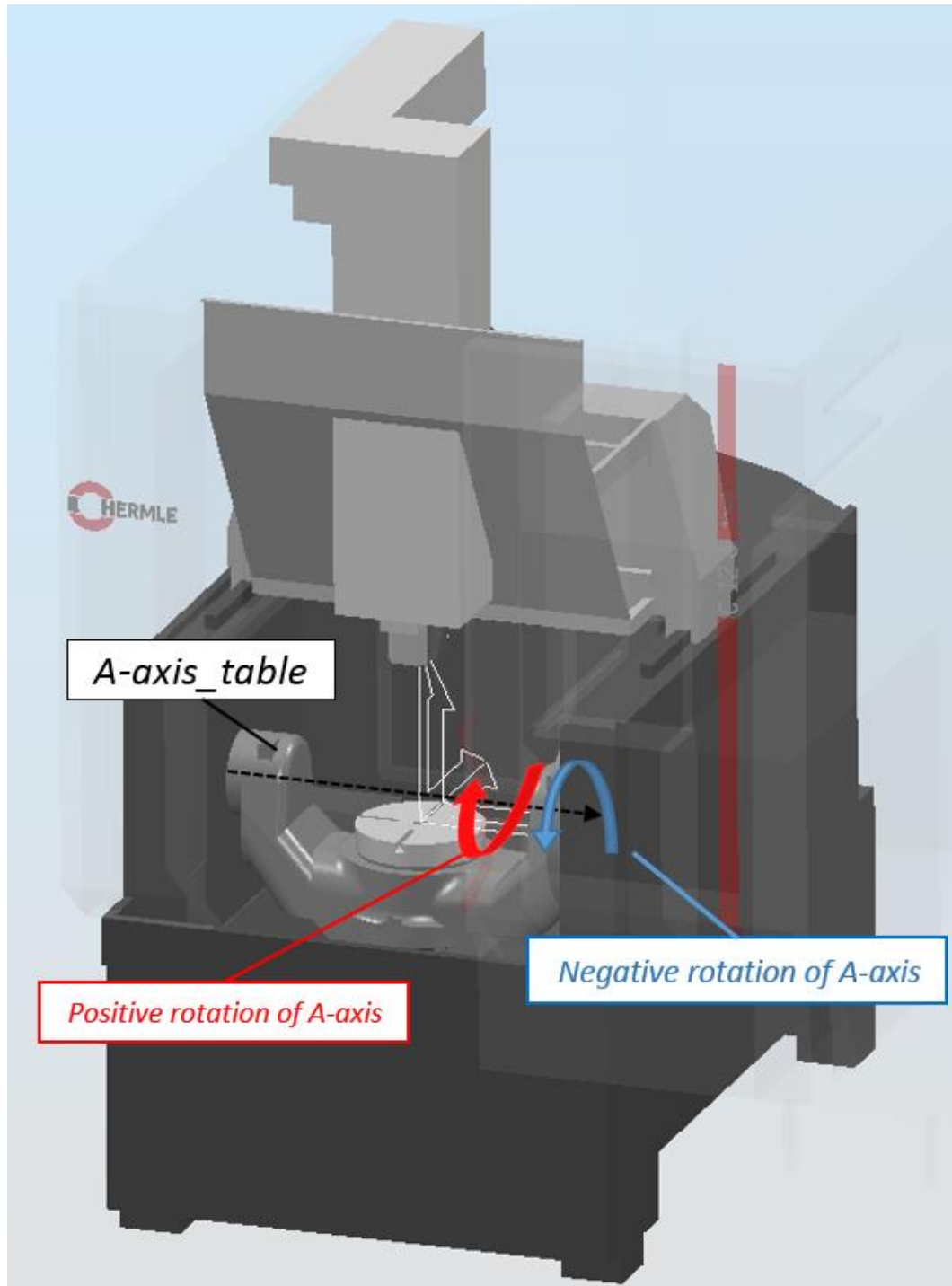

Let us open `A-axis_table` and `C-axis_table` in PowerShape. Then you can create new Local Coordinate System (LCS number 1) at  $X=0$   $Y=0$   $Z=0$ . This coordinate system duplicates the Global Coordinate System (GCS). See below.



*In PowerShape it is important to have the correct position of the activated coordinate system.*

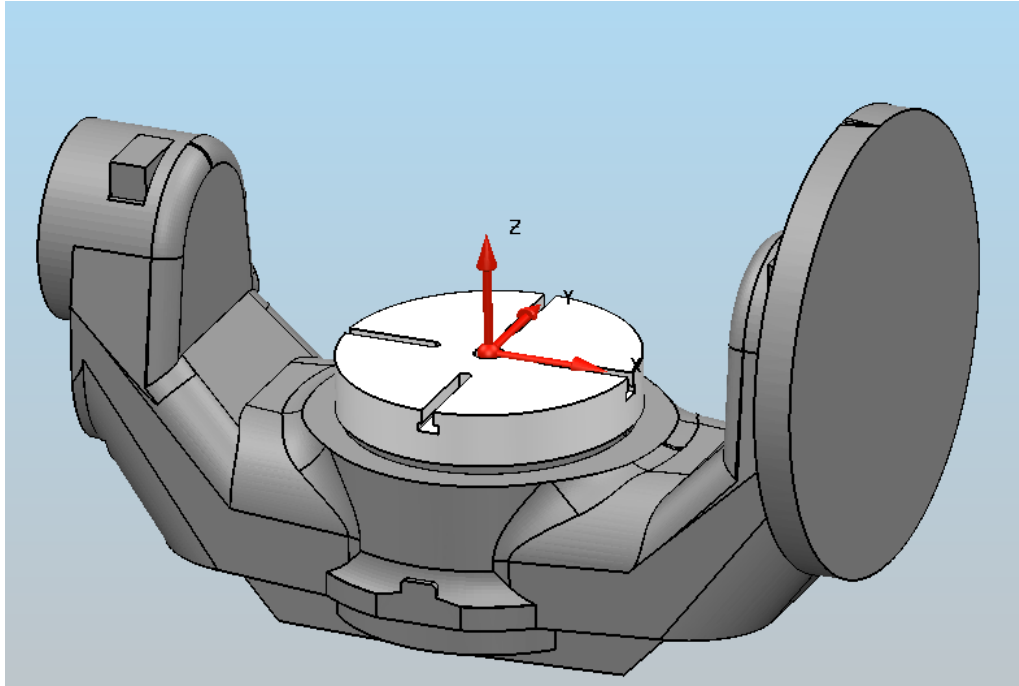

Then you must create some simple geometry (a line or an arc, for example) where you can easily identify the exact location for the centre of rotation:

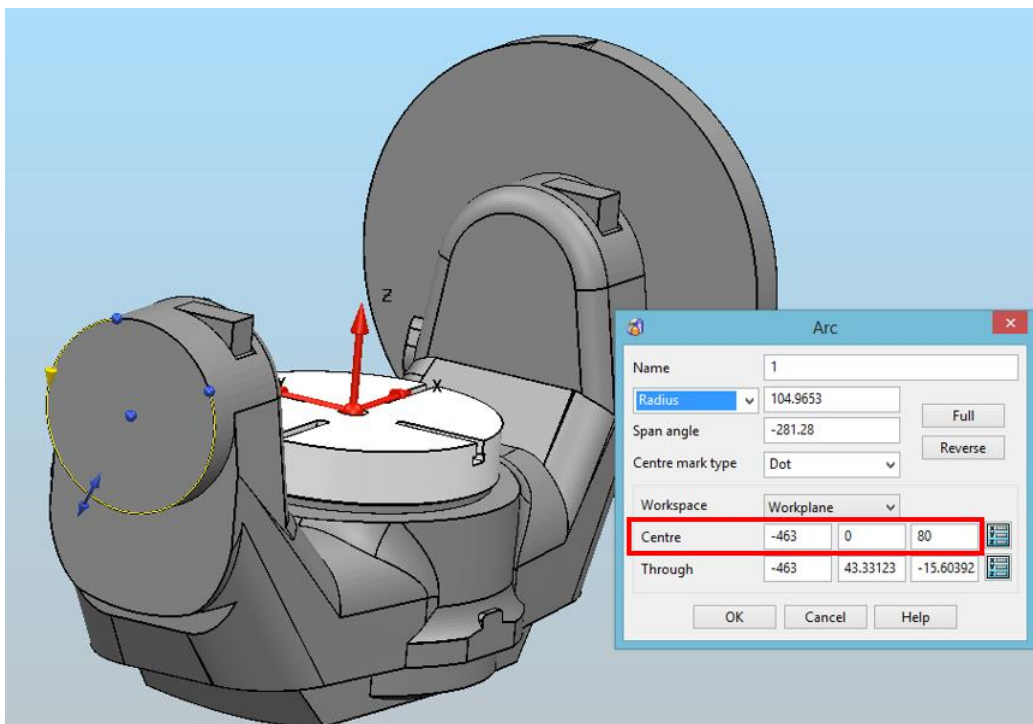

We can change the X value to 0 to move the arc to the centre of the table or just ignore it and keep it zero in the \*.mtd. As a result, we get:

```

<axis>
  <control_info ADDRESS="A" MIN="-115" MAX="115" />
  <simple_rotary X="0" Y="0" Z="80" I="-1" J="0" K="0" />
</axis>
<model_list>
  <dmt_file>
    <path FILE="Hermle_C12_SRT320/a-axis_table.dmt" />
    <rgb R="140" G="140" B="140"/>
  </dmt_file>
</model_list>

```

The centre of rotation of C-axis\_table:

```

<axis>
  <control_info ADDRESS="C" />
  <simple_rotary X="0" Y="0" Z="0" I="0" J="0" K="-1" />
</axis>
<model_list>
  <dmt_file>
    <path FILE="Hermle_C12_SRT320/c-axis_table.dmt" />
    <rgb R="200" G="200" B="200"/>
  </dmt_file>
</model_list>

```



*In some cases, it is difficult specify the correct position of the machine part (for example: poor quality geometry machine, wrong machine assembly). Use the specification of the machine tool to find the correct solution.*

Example with **Haas rotation table TR 210:**

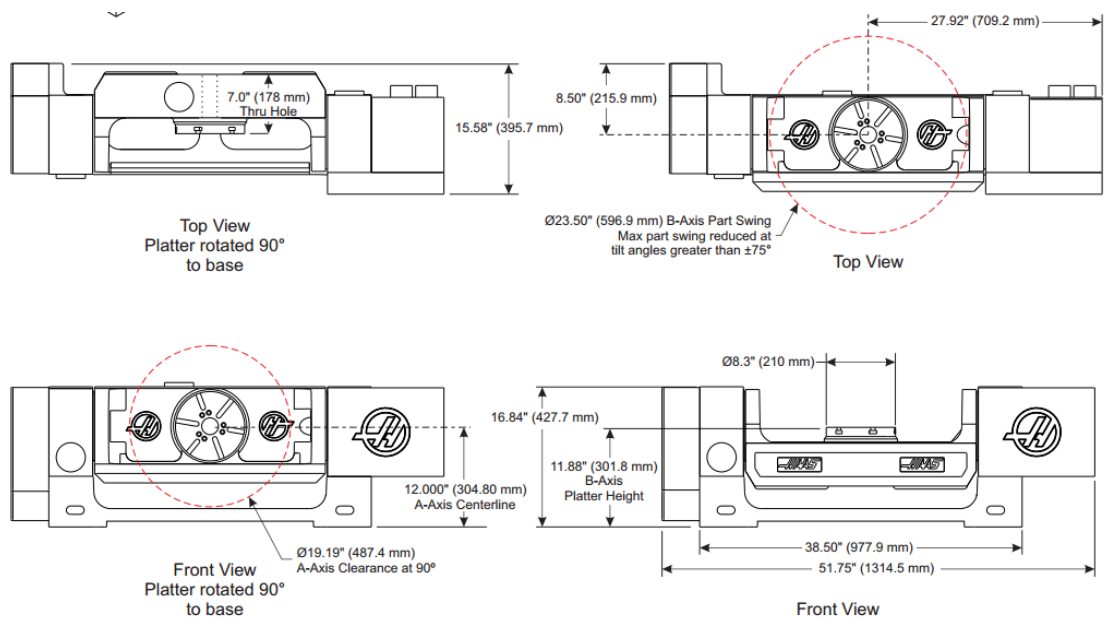

## Table-Table machine tools

Head-Table machine tool (DMG\_DMC\_80\_U2\_DuoBlock) without collinear vectors of rotation (the axes of rotation are not parallel to the axes of the global coordinate system).

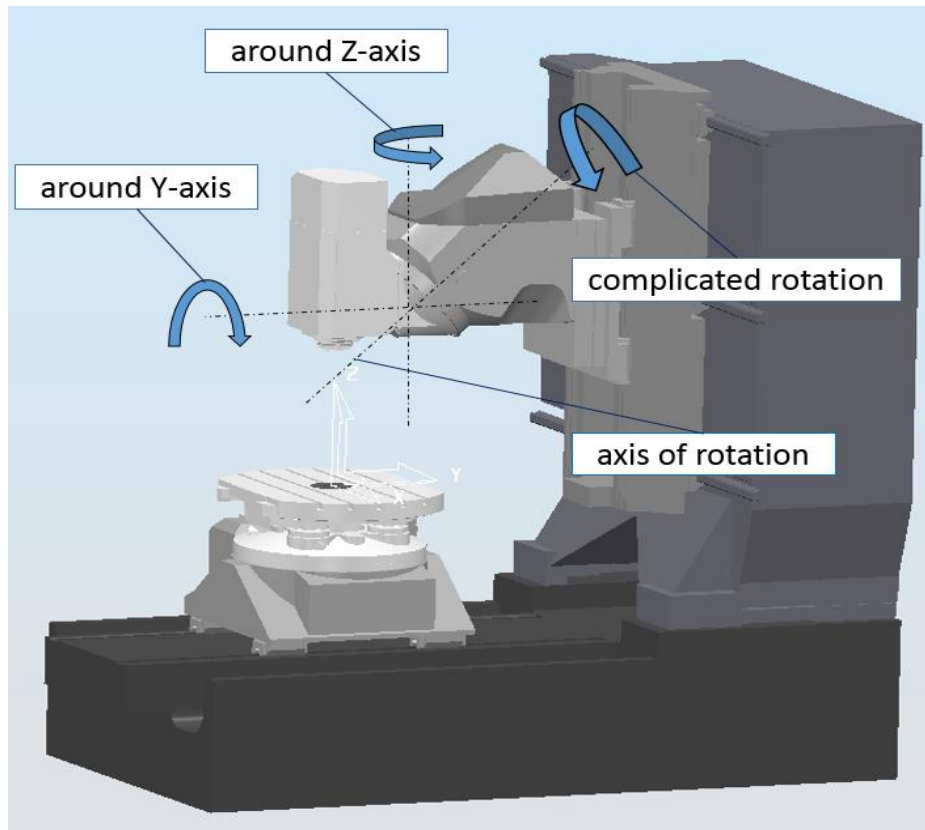

Such rotation is complicated because it consists of two rotational movements (around Z-axis and around Y-axis).

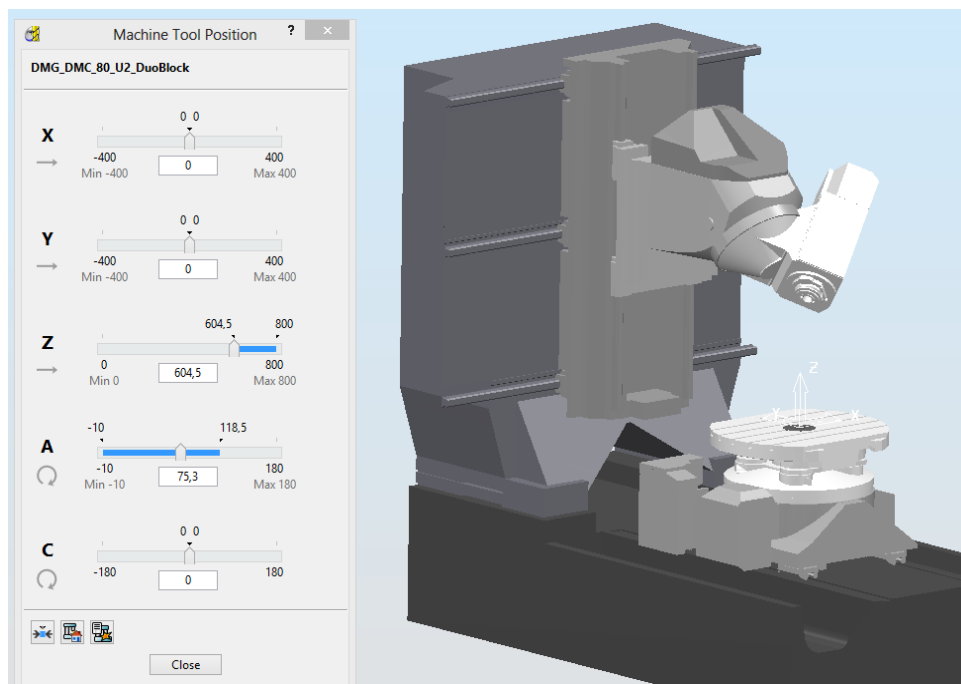

It is necessary to find the centre of rotation and the direction of motion. Consider the plane of rotation.

Let us create new local coordinate system (LCS-1) in the centre of table  $X=0$   $Y=0$   $Z=0$ . We then create some simple arcs where we can note the exact location of the centre of rotation:

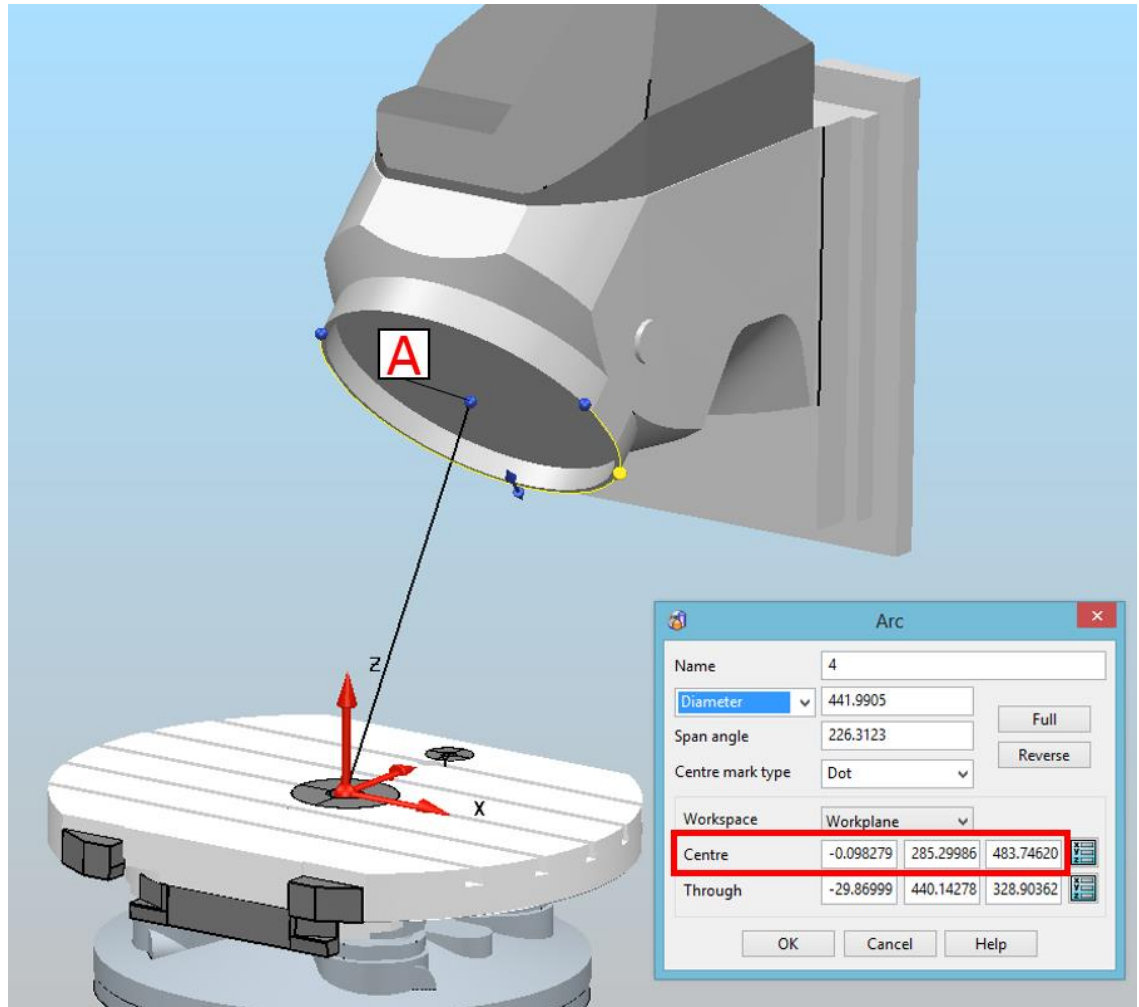

Double clicking on arc. The point **A** is centre of rotation with coordinates:  
 $X=-0.098279$   $Y=285.29986$   $Z=483.74620$ .

We use these coordinates to define centre of rotation.

At the centre of rotation (point **A**), we create local coordinate system (LCS-2) oriented like the global coordinate system. See below:

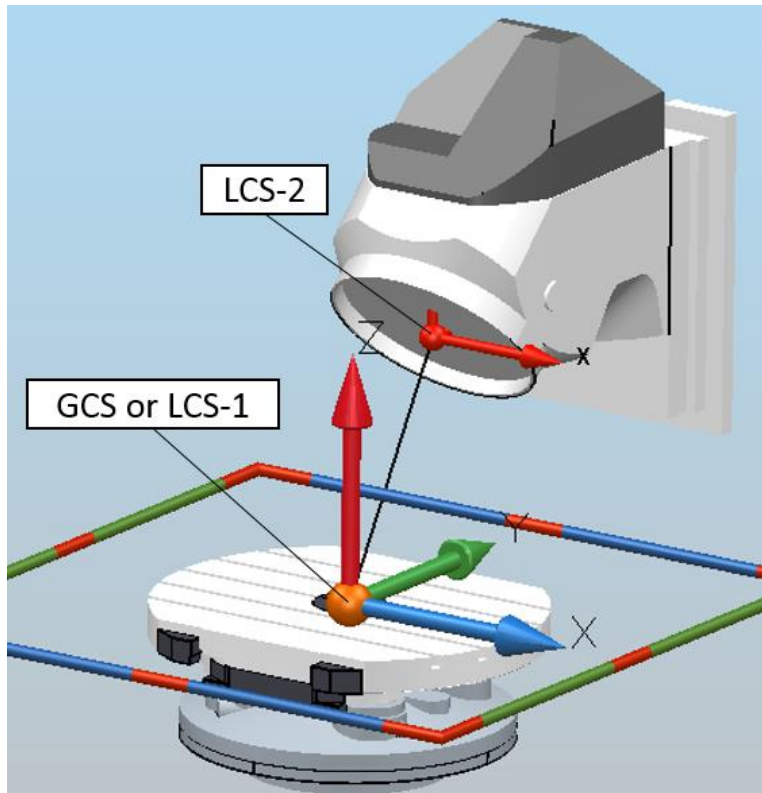

Then, create local coordinate system (LCS-3) at the point **A**, oriented perpendicular created arc (Z-axis should be perpendicular to the created arc):

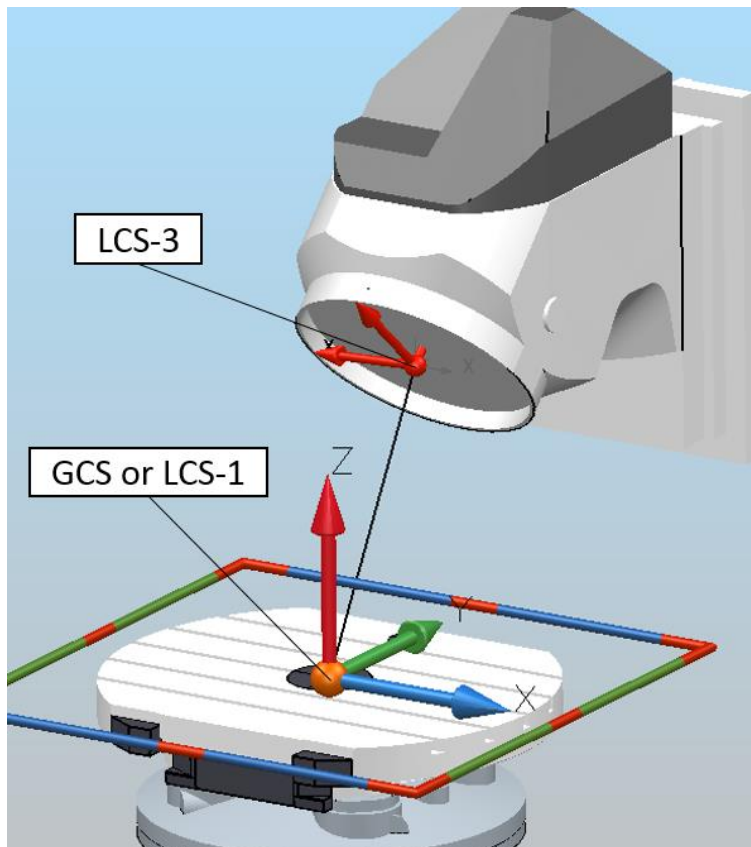

By using activated LCS-3 create short line (start point  $x=0$ ;  $y=0$ ;  $z=0$ ; and end point  $x=0$ ;  $y=0$ ;  $z=1$ )

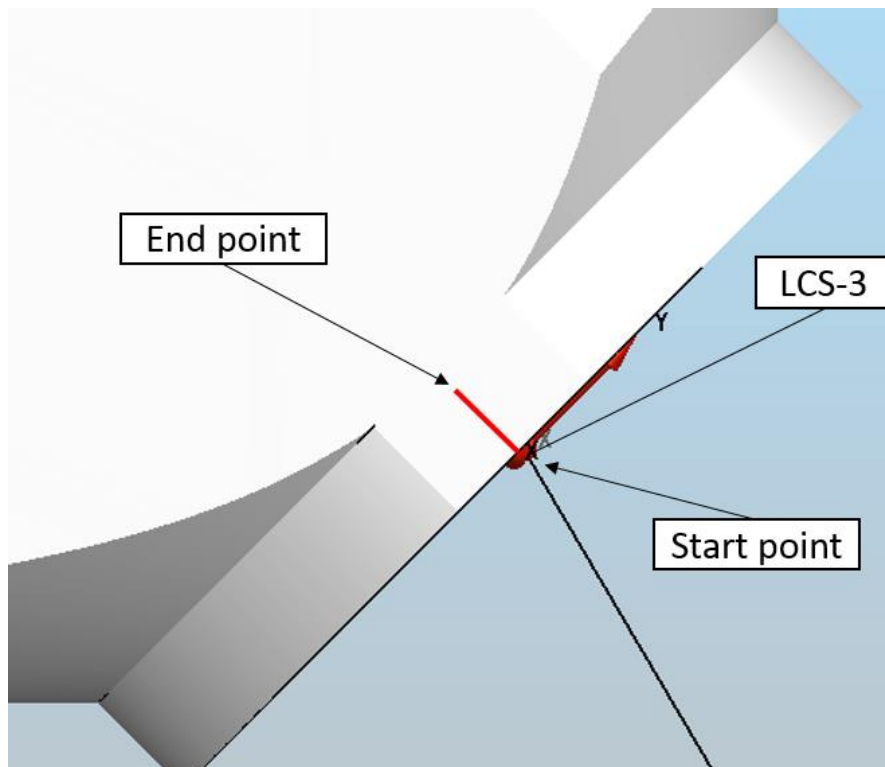

Then we activate LCS-2 and double click on short line. See result below:

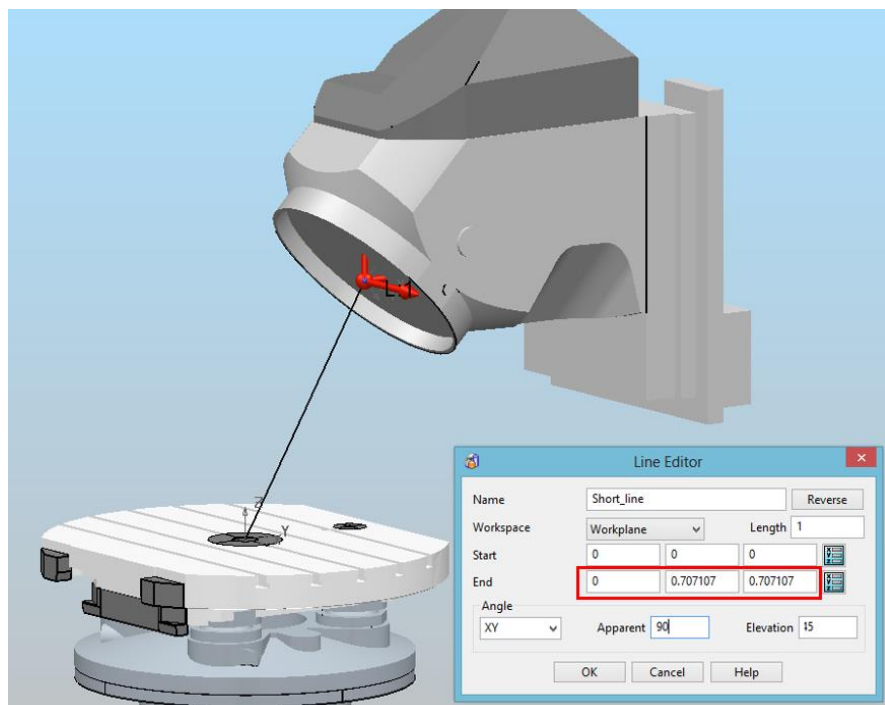

Where  $I=0$ ;  $J=0.707107$ ;  $K=0.707107$ . We find the direction of movement.

See screenshot below:

```
<machine_part>
  <axis>
    <control_info ADDRESS="A" VALUE="0" MIN="-10" MAX="180" />
    <simple_rotary X="-0.1" Y="285.3" Z="483.75" I="0" J="0.707107" K="0.707107" />
  </axis>
  <model_list>
    <dmf_file>
      <path FILE="DMG_DMC_80_U2_DuoBlock/B_Axis.dmf" />
    </dmf_file>
  </model_list>
</machine_part>
```

If the elevation is 45 degrees then we can use I=0; J=1; K=1.

Finally, use PowerMill and PostProcessor for testing the MTD (check the start and end point, correct position of all parts of machine, collision detection).

# Autodesk Legal Notice

© 2020 Autodesk, Inc. All Rights Reserved. Except where otherwise noted, this work is licensed under a Creative Commons Attribution-NonCommercial-ShareAlike 3.0 Unported License that can be viewed online at <http://creativecommons.org/licenses/by-nc-sa/3.0/>. This license content, applicable as of 16 December 2014 to this software product, is reproduced here for offline users:

CREATIVE COMMONS CORPORATION IS NOT A LAW FIRM AND DOES NOT PROVIDE LEGAL SERVICES. DISTRIBUTION OF THIS LICENSE DOES NOT CREATE AN ATTORNEY-CLIENT RELATIONSHIP. CREATIVE COMMONS PROVIDES THIS INFORMATION ON AN "AS-IS" BASIS. CREATIVE COMMONS MAKES NO WARRANTIES REGARDING THE INFORMATION PROVIDED, AND DISCLAIMS LIABILITY FOR DAMAGES RESULTING FROM ITS USE.

## License

THE WORK (AS DEFINED BELOW) IS PROVIDED UNDER THE TERMS OF THIS CREATIVE COMMONS PUBLIC LICENSE ("CCPL" OR "LICENSE"). THE WORK IS PROTECTED BY COPYRIGHT AND/OR OTHER APPLICABLE LAW. ANY USE OF THE WORK OTHER THAN AS AUTHORIZED UNDER THIS LICENSE OR COPYRIGHT LAW IS PROHIBITED.

BY EXERCISING ANY RIGHTS TO THE WORK PROVIDED HERE, YOU ACCEPT AND AGREE TO BE BOUND BY THE TERMS OF THIS LICENSE. TO THE EXTENT THIS LICENSE MAY BE CONSIDERED TO BE A CONTRACT, THE LICENSOR GRANTS YOU THE RIGHTS CONTAINED HERE IN CONSIDERATION OF YOUR ACCEPTANCE OF SUCH TERMS AND CONDITIONS.

## 1. Definitions

- a. "**Adaptation**" means a work based upon the Work, or upon the Work and other pre-existing works, such as a translation, adaptation, derivative work, arrangement of music or other alterations of a literary or artistic work, or phonogram or performance and includes cinematographic adaptations or any other form in which the Work may be recast, transformed, or adapted including in any form recognizably derived from the original, except that a work that constitutes a Collection will not be considered an Adaptation for the purpose of this License. For the avoidance of doubt, where the Work is a musical work, performance or phonogram, the synchronization of the Work in timed-relation with a moving image ("synching") will be considered an Adaptation for the purpose of this License.
- b. "**Collection**" means a collection of literary or artistic works, such as encyclopedias and anthologies, or performances, phonograms or broadcasts, or other works or subject matter other than works listed in Section 1(g) below, which, by reason of the selection and arrangement of their contents, constitute intellectual creations, in which the Work is included in its entirety in unmodified form along with one or more other contributions, each constituting separate and independent works in themselves, which together are assembled into a collective whole. A work that constitutes a Collection will not be considered an Adaptation (as defined above) for the purposes of this License.
- c. "**Distribute**" means to make available to the public the original and copies of the Work or Adaptation, as appropriate, through sale or other transfer of ownership.
- d. "**License Elements**" means the following high-level license attributes as selected by Licensor and indicated in the title of this License: Attribution, Noncommercial, ShareAlike.
- e. "**Licensor**" means the individual, individuals, entity or entities that offer(s) the Work under the terms of this License.
- f. "**Original Author**" means, in the case of a literary or artistic work, the individual, individuals, entity or entities who created the Work or if no individual or entity can be identified, the publisher; and in addition (i) in the case of a performance the actors, singers, musicians, dancers, and other persons who act, sing, deliver, declaim, play in, interpret or otherwise perform literary or artistic works or expressions of folklore; (ii) in the case of a phonogram the producer being the person or legal entity who first fixes the sounds of a performance or other sounds; and, (iii) in the case of broadcasts, the organization that transmits the broadcast.

g. **"Work"** means the literary and/or artistic work offered under the terms of this License including without limitation any production in the literary, scientific and artistic domain, whatever may be the mode or form of its expression including digital form, such as a book, pamphlet and other writing; a lecture, address, sermon or other work of the same nature; a dramatic or dramatico-musical work; a choreographic work or entertainment in dumb show; a musical composition with or without words; a cinematographic work to which are assimilated works expressed by a process analogous to cinematography; a work of drawing, painting, architecture, sculpture, engraving or lithography; a photographic work to which are assimilated works expressed by a process analogous to photography; a work of applied art; an illustration, map, plan, sketch or three-dimensional work relative to geography, topography, architecture or science; a performance; a broadcast; a phonogram; a compilation of data to the extent it is protected as a copyrightable work; or a work performed by a variety or circus performer to the extent it is not otherwise considered a literary or artistic work.

h. **"You"** means an individual or entity exercising rights under this License who has not previously violated the terms of this License with respect to the Work, or who has received express permission from the Licensor to exercise rights under this License despite a previous violation.

i. **"Publicly Perform"** means to perform public recitations of the Work and to communicate to the public those public recitations, by any means or process, including by wire or wireless means or public digital performances; to make available to the public Works in such a way that members of the public may access these Works from a place and at a place individually chosen by them; to perform the Work to the public by any means or process and the communication to the public of the performances of the Work, including by public digital performance; to broadcast and rebroadcast the Work by any means including signs, sounds or images.

j. **"Reproduce"** means to make copies of the Work by any means including without limitation by sound or visual recordings and the right of fixation and reproducing fixations of the Work, including storage of a protected performance or phonogram in digital form or other electronic medium.

**2. Fair Dealing Rights.** Nothing in this License is intended to reduce, limit, or restrict any uses free from copyright or rights arising from limitations or exceptions that are provided for in connection with the copyright protection under copyright law or other applicable laws.

**3. License Grant.** Subject to the terms and conditions of this License, Licensor hereby grants You a worldwide, royalty-free, non-exclusive, perpetual (for the duration of the applicable copyright) license to exercise the rights in the Work as stated below:

- a. to Reproduce the Work, to incorporate the Work into one or more Collections, and to Reproduce the Work as incorporated in the Collections;
- b. to create and Reproduce Adaptations provided that any such Adaptation, including any translation in any medium, takes reasonable steps to clearly label, demarcate or otherwise identify that changes were made to the original Work. For example, a translation could be marked "The original work was translated from English to Spanish," or a modification could indicate "The original work has been modified.";
- c. to Distribute and Publicly Perform the Work including as incorporated in Collections; and,
- d. to Distribute and Publicly Perform Adaptations.

The above rights may be exercised in all media and formats whether now known or hereafter devised. The above rights include the right to make such modifications as are technically necessary to exercise the rights in other media and formats. Subject to Section 8(f), all rights not expressly granted by Licensor are hereby reserved, including but not limited to the rights described in Section 4(e).

**4. Restrictions.** The license granted in Section 3 above is expressly made subject to and limited by the following restrictions:

a. You may Distribute or Publicly Perform the Work only under the terms of this License. You must include a copy of, or the Uniform Resource Identifier (URI) for, this License with every copy of the Work You Distribute or Publicly Perform. You may not offer or impose any terms on the Work that restrict the terms of this License or the ability of the recipient of the Work to exercise the rights granted to that recipient under the terms of the License. You may not sublicense the Work. You must keep intact all notices that refer to this License and to the disclaimer of warranties with every copy of the Work You Distribute or Publicly Perform. When You Distribute or Publicly Perform the Work, You may not impose any effective technological measures on the Work that restrict the ability of a recipient of the Work from You to exercise the rights granted to that recipient under the terms of the License. This Section 4(a) applies to the Work as incorporated in a Collection, but this does not require the Collection apart from the Work itself to be made subject to the terms of this License. If You create a Collection, upon notice from any Licensor You must, to the extent practicable, remove from the Collection any credit as required by Section 4(d), as requested. If You create an Adaptation, upon notice from any Licensor You must, to the extent practicable, remove from the Adaptation any credit as required by Section 4(d), as requested.

b. You may Distribute or Publicly Perform an Adaptation only under: (i) the terms of this License; (ii) a later version of this License with the same License Elements as this License; (iii) a Creative Commons jurisdiction license (either this or a later license version) that contains the same License Elements as this License (e.g., Attribution-NonCommercial-ShareAlike 3.0 US) ("Applicable License"). You must include a copy of, or the URI, for Applicable License with every copy of each Adaptation You Distribute or Publicly Perform. You may not offer or impose any terms on the Adaptation that restrict the terms of the Applicable License or the ability of the recipient of the Adaptation to exercise the rights granted to that recipient under the terms of the Applicable License. You must keep intact all notices that refer to the Applicable License and to the disclaimer of warranties with every copy of the Work as included in the Adaptation You Distribute or Publicly Perform. When You Distribute or Publicly Perform the Adaptation, You may not impose any effective technological measures on the Adaptation that restrict the ability of a recipient of the Adaptation from You to exercise the rights granted to that recipient under the terms of the Applicable License. This Section 4(b) applies to the Adaptation as incorporated in a Collection, but this does not require the Collection apart from the Adaptation itself to be made subject to the terms of the Applicable License.

c. You may not exercise any of the rights granted to You in Section 3 above in any manner that is primarily intended for or directed toward commercial advantage or private monetary compensation. The exchange of the Work for other copyrighted works by means of digital file-sharing or otherwise shall not be considered to be intended for or directed toward commercial advantage or private monetary compensation, provided there is no payment of any monetary compensation in connection with the exchange of copyrighted works.

d. If You Distribute, or Publicly Perform the Work or any Adaptations or Collections, You must, unless a request has been made pursuant to Section 4(a), keep intact all copyright notices for the Work and provide, reasonable to the medium or means You are utilizing: (i) the name of the Original Author (or pseudonym, if applicable) if supplied, and/or if the Original Author and/or Licensor designate another party or parties (e.g., a sponsor institute, publishing entity, journal) for attribution ("Attribution Parties") in Licensor's copyright notice, terms of service or by other reasonable means, the name of such party or parties; (ii) the title of the Work if supplied; (iii) to the extent reasonably practicable, the URI, if any, that Licensor specifies to be associated with the Work, unless such URI does not refer to the copyright notice or licensing information for the Work; and, (iv) consistent with Section 3(b), in the case of an Adaptation, a credit identifying the use of the Work in the Adaptation (e.g., "French translation of the Work by Original Author," or "Screenplay based on original Work by Original Author"). The credit required by this Section 4(d) may be implemented in any reasonable manner; provided, however, that in the case of a Adaptation or Collection, at a minimum such credit will appear, if a credit for all contributing authors of the Adaptation or Collection appears, then as part of these credits and in a manner at least as prominent as the credits for the other contributing authors. For the avoidance of doubt, You may only use the credit required by this Section for the purpose of attribution in the manner set out above and, by exercising Your rights under this License, You may not implicitly or explicitly assert or imply any connection with, sponsorship or endorsement by the Original Author, Licensor and/or Attribution Parties, as appropriate, of You or Your use of the Work, without the separate, express prior written permission of the Original Author, Licensor and/or Attribution Parties.

e. For the avoidance of doubt:

i. Non-waivable Compulsory License Schemes. In those jurisdictions in which the right to collect royalties through any statutory or compulsory licensing scheme cannot be waived, the Licensor reserves the exclusive right to collect such royalties for any exercise by You of the rights granted under this License;

- ii. Waivable Compulsory License Schemes. In those jurisdictions in which the right to collect royalties through any statutory or compulsory licensing scheme can be waived, the Licensor reserves the exclusive right to collect such royalties for any exercise by You of the rights granted under this License if Your exercise of such rights is for a purpose or use which is otherwise than noncommercial as permitted under Section 4(c) and otherwise waives the right to collect royalties through any statutory or compulsory licensing scheme; and,
- iii. Voluntary License Schemes. The Licensor reserves the right to collect royalties, whether individually or, in the event that the Licensor is a member of a collecting society that administers voluntary licensing schemes, via that society, from any exercise by You of the rights granted under this License that is for a purpose or use which is otherwise than noncommercial as permitted under Section 4(c).

f. Except as otherwise agreed in writing by the Licensor or as may be otherwise permitted by applicable law, if You Reproduce, Distribute or Publicly Perform the Work either by itself or as part of any Adaptations or Collections, You must not distort, mutilate, modify or take other derogatory action in relation to the Work which would be prejudicial to the Original Author's honor or reputation. Licensor agrees that in those jurisdictions (e.g. Japan), in which any exercise of the right granted in Section 3(b) of this License (the right to make Adaptations) would be deemed to be a distortion, mutilation, modification or other derogatory action prejudicial to the Original Author's honor and reputation, the Licensor will waive or not assert, as appropriate, this Section, to the fullest extent permitted by the applicable national law, to enable You to reasonably exercise Your right under Section 3(b) of this License (right to make Adaptations) but not otherwise.

## **5. Representations, Warranties and Disclaimer**

UNLESS OTHERWISE MUTUALLY AGREED TO BY THE PARTIES IN WRITING AND TO THE FULLEST EXTENT PERMITTED BY APPLICABLE LAW, LICENSOR OFFERS THE WORK AS-IS AND MAKES NO REPRESENTATIONS OR WARRANTIES OF ANY KIND CONCERNING THE WORK, EXPRESS, IMPLIED, STATUTORY OR OTHERWISE, INCLUDING, WITHOUT LIMITATION, WARRANTIES OF TITLE, MERCHANTABILITY, FITNESS FOR A PARTICULAR PURPOSE, NONINFRINGEMENT, OR THE ABSENCE OF LATENT OR OTHER DEFECTS, ACCURACY, OR THE PRESENCE OF ABSENCE OF ERRORS, WHETHER OR NOT DISCOVERABLE. SOME JURISDICTIONS DO NOT ALLOW THE EXCLUSION OF IMPLIED WARRANTIES, SO THIS EXCLUSION MAY NOT APPLY TO YOU.

**6. Limitation on Liability.** EXCEPT TO THE EXTENT REQUIRED BY APPLICABLE LAW, IN NO EVENT WILL LICENSOR BE LIABLE TO YOU ON ANY LEGAL THEORY FOR ANY SPECIAL, INCIDENTAL, CONSEQUENTIAL, PUNITIVE OR EXEMPLARY DAMAGES ARISING OUT OF THIS LICENSE OR THE USE OF THE WORK, EVEN IF LICENSOR HAS BEEN ADVISED OF THE POSSIBILITY OF SUCH DAMAGES.

## **7. Termination**

a. This License and the rights granted hereunder will terminate automatically upon any breach by You of the terms of this License. Individuals or entities who have received Adaptations or Collections from You under this License, however, will not have their licenses terminated provided such individuals or entities remain in full compliance with those licenses. Sections 1, 2, 5, 6, 7, and 8 will survive any termination of this License.

b. Subject to the above terms and conditions, the license granted here is perpetual (for the duration of the applicable copyright in the Work). Notwithstanding the above, Licensor reserves the right to release the Work under different license terms or to stop distributing the Work at any time; provided, however that any such election will not serve to withdraw this License (or any other license that has been, or is required to be, granted under the terms of this License), and this License will continue in full force and effect unless terminated as stated above.

## **8. Miscellaneous**

a. Each time You Distribute or Publicly Perform the Work or a Collection, the Licensor offers to the recipient a license to the Work on the same terms and conditions as the license granted to You under this License.

b. Each time You Distribute or Publicly Perform an Adaptation, Licensor offers to the recipient a license to the original Work on the same terms and conditions as the license granted to You under this License.

c. If any provision of this License is invalid or unenforceable under applicable law, it shall not affect the validity or enforceability of the remainder of the terms of this License, and without further action by the parties to this agreement, such provision shall be reformed to the minimum extent necessary to make such provision valid and enforceable.

d. No term or provision of this License shall be deemed waived and no breach consented to unless such waiver or consent shall be in writing and signed by the party to be charged with such waiver or consent.

e. This License constitutes the entire agreement between the parties with respect to the Work licensed here. There are no understandings, agreements or representations with respect to the Work not specified here. Licensor shall not be bound by any additional provisions that may appear in any communication from You. This License may not be modified without the mutual written agreement of the Licensor and You.

f. The rights granted under, and the subject matter referenced, in this License were drafted utilizing the terminology of the Berne Convention for the Protection of Literary and Artistic Works (as amended on September 28, 1979), the Rome Convention of 1961, the WIPO Copyright Treaty of 1996, the WIPO Performances and Phonograms Treaty of 1996 and the Universal Copyright Convention (as revised on July 24, 1971). These rights and subject matter take effect in the relevant jurisdiction in which the License terms are sought to be enforced according to the corresponding provisions of the implementation of those treaty provisions in the applicable national law. If the standard suite of rights granted under applicable copyright law includes additional rights not granted under this License, such additional rights are deemed to be included in the License; this License is not intended to restrict the license of any rights under applicable law.

### **Creative Commons Notice**

Creative Commons is not a party to this License, and makes no warranty whatsoever in connection with the Work. Creative Commons will not be liable to You or any party on any legal theory for any damages whatsoever, including without limitation any general, special, incidental or consequential damages arising in connection to this license. Notwithstanding the foregoing two (2) sentences, if Creative Commons has expressly identified itself as the Licensor hereunder, it shall have all rights and obligations of Licensor.

Except for the limited purpose of indicating to the public that the Work is licensed under the CCPL, Creative Commons does not authorize the use by either party of the trademark "Creative Commons" or any related trademark or logo of Creative Commons without the prior written consent of Creative Commons. Any permitted use will be in compliance with Creative Commons' then-current trademark usage guidelines, as may be published on its website or otherwise made available upon request from time to time. For the avoidance of doubt, this trademark restriction does not form part of this License.

Creative Commons may be contacted at <http://creativecommons.org/>.

Certain materials included in this publication are reprinted with the permission of the copyright holder.

### **Creative Commons FAQ**

Autodesk's Creative Commons FAQ can be viewed online at <https://knowledge.autodesk.com/customer-service/share-the-knowledge>, and is reproduced here for offline users.

Creative Commons is a simple, open licensing model which allows individuals to freely modify, remix, and share digital content created for learning and support.

Borrow from the Autodesk Learning, Support and Video libraries to build a new learning experience for anyone with any particular need or interest. It's out there. You can use it. It's yours.

In collaboration with Creative Commons, Autodesk invites you to share your knowledge with the rest of the world, inspiring others to learn, achieve goals, and ignite creativity.

### **What is Creative Commons?**

Creative Commons (CC) is a nonprofit organization that offers a simple licensing model that frees digital content to enable anyone to modify, remix, and share creative works.

### **How do I know if Autodesk learning content and Autodesk University content is available under Creative Commons?**

All Autodesk learning content and Autodesk University content released under Creative Commons is explicitly marked with a Creative Commons icon specifying what you can and cannot do. Always follow the terms of the stated license.

### **What Autodesk learning content is currently available under Creative Commons?**

Over time, Autodesk will release more and more learning content under the Creative Commons licenses.

Currently available learning content:

- Autodesk online help-Online help for many Autodesk products, including its embedded media such as images and help movies.
- Autodesk Learning Videos-A range of video-based learning content, including the video tutorials on the Autodesk YouTube™ Learning Channels and their associated iTunes® podcasts.
- Autodesk downloadable materials-Downloadable 3D assets, digital footage, and other files you can use to follow along on your own time.

### **Is Autodesk learning and support content copyrighted?**

Yes. Creative Commons licensing does not replace copyright. Copyright remains with Autodesk or its suppliers, as applicable. But it makes the terms of use much more flexible.

### **What do the Autodesk Creative Commons licenses allow?**

Autodesk makes some of its learning and support content available under two distinct Creative Commons licenses. The learning content is clearly marked with the applicable Creative Commons license.

You must comply with the following conditions:

- **Attribution-NonCommercial-ShareAlike (CC BY-NC-SA)** This license lets you copy, distribute, display, remix, tweak, and build upon our work noncommercially, as long as you credit Autodesk and license your new creations under the identical terms. Terms of this license can be viewed online at <https://creativecommons.org/licenses/by-nc-sa/3.0/us/>
- **Attribution-NonCommercial-No Derivative Works (CC BY-NC-ND)** This license lets you copy, distribute, and display only verbatim copies of our work as long as you credit us, but you cannot alter the learning content in any way or use it commercially. Terms of this license can be viewed online at [https://creativecommons.org/licenses/by-nc-nd/3.0/us/deed.en\\_US](https://creativecommons.org/licenses/by-nc-nd/3.0/us/deed.en_US)
- **Special permissions on content marked as No Derivative Works** For video-based learning content marked as No Derivative Works (ND), Autodesk grants you special permission to make modifications but only for the purpose of translating the video content into another language.

These conditions can be modified only by explicit permission of Autodesk, Inc. Send requests for modifications outside of these license terms to [creativecommons@autodesk.com](mailto:creativecommons@autodesk.com).

### **Can I get special permission to do something different with the learning content?**

Unless otherwise stated, our Creative Commons conditions can be modified only by explicit permission of Autodesk, Inc. If you have any questions or requests for modifications outside of these license terms, email us at [creativecommons@autodesk.com](mailto:creativecommons@autodesk.com).

## **How do I attribute Autodesk learning content?**

You must explicitly credit Autodesk, Inc., as the original source of the materials. This is a standard requirement of the Attribution (BY) term in all Creative Commons licenses. In some cases, such as for the Autodesk video learning content, we specify exactly how we would like to be attributed.

This is usually described on the video's end-plate. For the most part providing the title of the work, the URL where the work is hosted, and a credit to Autodesk, Inc., is quite acceptable. Also, remember to keep intact any copyright notice associated with the work. This may sound like a lot of information, but there is flexibility in the way you present it.

Here are some examples:

"This document contains content adapted from the Autodesk® Maya® Help, available under a Creative Commons Attribution-NonCommercial-Share Alike license. Copyright © Autodesk, Inc."

"This is a Finnish translation of a video created by the Autodesk Maya Learning Channel @ [www.youtube.com/mayahowtos](http://www.youtube.com/mayahowtos). Copyright © Autodesk, Inc."

"Special thanks to the Autodesk® 3ds Max® Learning Channel @ [www.youtube.com/3dsmaxhowtos](http://www.youtube.com/3dsmaxhowtos). Copyright © Autodesk, Inc."

## **Do I follow YouTube's standard license or Autodesk's Creative Commons license?**

The videos of the Autodesk Learning Channels on YouTube are uploaded under YouTube's standard license policy. Nonetheless, these videos are released by Autodesk as Creative Commons Attribution-NonCommercial-No Derivative Works (CC BY-NC-ND) and are marked as such.

You are free to use our video learning content according to the Creative Commons license under which they are released.

## **Where can I easily download Autodesk learning videos?**

Most of the Autodesk Learning Channels have an associated iTunes podcast from where you can download the same videos and watch them offline. When translating Autodesk learning videos, we recommend downloading the videos from the iTunes podcasts.

### **Can I translate Autodesk learning videos?**

Yes. Even though our learning videos are licensed as No Derivative Works (ND), we grant everyone permission to translate the audio and subtitles into other languages. In fact, if you want to recapture the video tutorial as-is but show the user interface in another language, you are free to do so. Be sure to give proper attribution as indicated on the video's Creative Commons end-plate. This special permission only applies to translation projects. Requests for modifications outside of these license terms can be directed to [creativecommons@autodesk.com](mailto:creativecommons@autodesk.com).

### **How do I let others know that I have translated Autodesk learning content into another language?**

Autodesk is happy to see its learning content translated into as many different languages as possible. If you translate our videos or any of our learning content into other languages, let us know. We can help promote your contributions to our growing multilingual community. In fact, we encourage you to find creative ways to share our learning content with your friends, family, students, colleagues, and communities around the world. Contact us at [creativecommons@autodesk.com](mailto:creativecommons@autodesk.com).

### **I have translated Autodesk learning videos into other languages. Can I upload them to my own YouTube channel?**

Yes, please do and let us know where to find them so that we can help promote your contributions to our growing multilingual Autodesk community. Contact us at [creativecommons@autodesk.com](mailto:creativecommons@autodesk.com).

### **Can I repost or republish Autodesk learning content on my site or blog?**

Yes, you can make Autodesk learning material available on your site or blog as long as you follow the terms of the Creative Commons license under which the learning content is released. If you are simply referencing the learning content as-is, then we recommend that you link to it or embed it from where it is hosted by Autodesk. That way the content will always be fresh. If you have translated or remixed our learning content, then by all means you can host it yourself. Let us know about it, and we can help promote your contributions to our global learning community. Contact us at [creativecommons@autodesk.com](mailto:creativecommons@autodesk.com).

### **Can I show Autodesk learning content during my conference?**

Yes, as long as it's within the scope of a noncommercial event, and as long as you comply with the terms of the Creative Commons license outlined above. In particular, the videos must be shown unedited with the exception of modifications for the purpose of translation. If you wish to use Autodesk learning content in a commercial context, contact us with a request for permission at [creativecommons@autodesk.com](mailto:creativecommons@autodesk.com).

### **Can I use Autodesk learning content in my classroom?**

Yes, as long as you comply with the terms of the Creative Commons license under which the learning material is released. Many teachers use Autodesk learning content to stimulate discussions with students or to complement course materials, and we encourage you to do so as well.

### **Can I re-edit and remix Autodesk video learning content?**

No, but for one exception. Our Creative Commons BY-NC-ND license clearly states that "derivative works" of any kind (edits, cuts, remixes, mashups, and so on) are not allowed without explicit permission from Autodesk. This is essential for preserving the integrity of our instructors' ideas. However, we do give you permission to modify our videos for the purpose of translating them into other languages.

### **Can I re-edit and remix Autodesk downloadable 3D assets and footage?**

Yes. The Autodesk Learning Channels on YouTube provide downloadable 3D assets, footage, and other files for you to follow along with the video tutorials on your own time. This downloadable material is made available under a Creative Commons Attribution-NonCommercial-ShareAlike (CC BY-NC-SA) license. You can download these materials and experiment with them, but your remixes must give us credit as the original source of the content and be shared under the identical license terms.

### **Can I use content from Autodesk online help to create new materials for a specific audience?**

Yes, if you want to help a specific audience learn how to optimize the use of their Autodesk software, there is no need to start from scratch. You can use, remix, or enrich the relevant help content and include it in your book, instructions, examples, or workflows you create, then Share-Alike with the community. Always be sure to comply with the terms of the Creative Commons license under which the learning content is released.

## What are the best practices for marking content with Creative Commons Licenses?

When reusing a CC-licensed work (by sharing the original or a derivative based on the original), it is important to keep intact any copyright notice associated with the work, including the Creative Commons license being used. Make sure you abide by the license conditions provided by the licensor, in this case Autodesk, Inc.

### Trademarks

The following are registered trademarks or trademarks of Autodesk, Inc., and/or its subsidiaries and/or affiliates in the USA and other countries: 123D, 3ds Max, ADSK, Alias, ArtCAM, ATC, AutoCAD LT, AutoCAD, Autodesk, the Autodesk logo, Autodesk 123D, Autodesk Alias, Autodesk Forge, Autodesk Fusion, Autodesk Inventor, AutoSnap, BIM 360, Buzzsaw, CADmep, CAMduct, Civil 3D, Configurator 360, Dancing Baby (image), DWF, DWG, DWG (design/logo), DWG Extreme, DWG TrueConvert, DWG TrueView, DWGX, DXF, Eagle, ESTmep, FBX, FeatureCAM, Flame, FormIt 360, Fusion 360, The Future of Making Things, Glue, Green Building Studio, InfraWorks, Instructables, Instructables (stylized robot design/logo), Inventor, Inventor HSM, Inventor LT, Make Anything, Maya, Maya LT, Moldflow, MotionBuilder, Mudbox, Navisworks, Netfabb, Opticore, PartMaker, Pier 9, PowerInspect, PowerMill, PowerShape, Publisher 360, RasterDWG, RealDWG, ReCap, ReCap 360, Remake, Revit LT, Revit, Scaleform, Shotgun, Showcase, Showcase 360, SketchBook, Softimage, Tinkercad, TrustedDWG, VRED.

All other brand names, product names or trademarks belong to their respective holders.

### Disclaimer

THIS PUBLICATION AND THE INFORMATION CONTAINED HEREIN IS MADE AVAILABLE BY AUTODESK, INC. "AS IS." AUTODESK, INC. DISCLAIMS ALL WARRANTIES, EITHER EXPRESS OR IMPLIED, INCLUDING BUT NOT LIMITED TO ANY IMPLIED WARRANTIES OF MERCHANTABILITY OR FITNESS FOR A PARTICULAR PURPOSE REGARDING THESE MATERIALS.



*Except where otherwise noted, this work is licensed under a Creative Commons Attribution-NonCommercial-ShareAlike 3.0 Unported License. Please see the Autodesk Creative Commons FAQ for more information.*